

ET9759 CAD Drawing

1.0/2.3 Plug Right Angle Connector Crimp/Solder Attachment for RG174, RG316, RG188, LMR-100, PE-B100, PE-C100, 0.100 inch

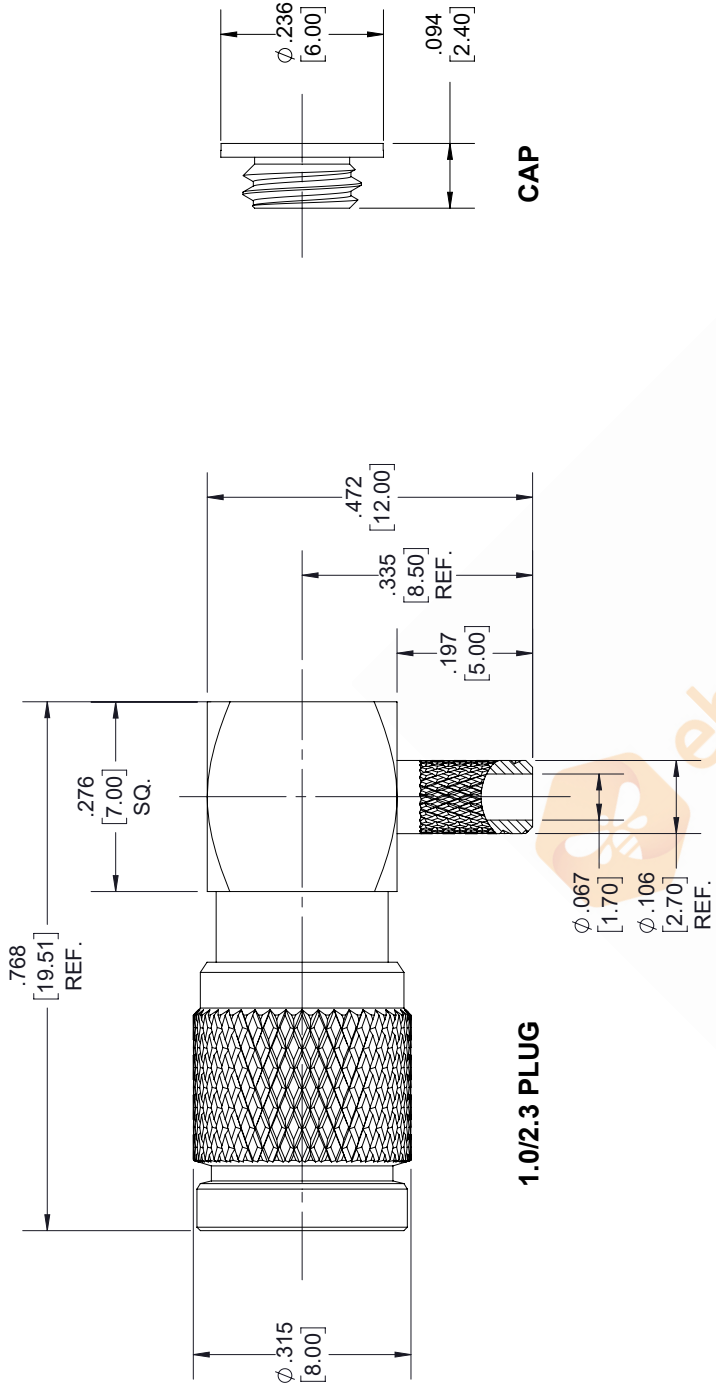

1.0/2.3 PLUG

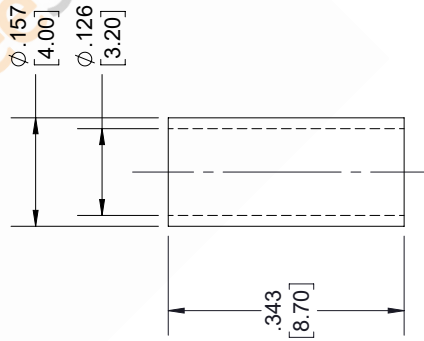
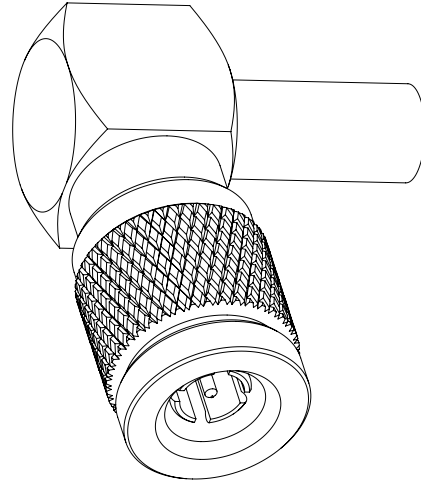

FERRULE

STANDARD TOLERANCES

- .X ±0.2
- .XX ±0.01
- .XXX ±0.005

*STANDARD TOLERANCES APPLY ONLY TO DIMENSIONS IN INCHES

NOTES:
 1. UNLESS OTHERWISE SPECIFIED ALL DIMENSIONS ARE NOMINAL.
 2. ALL SPECIFICATIONS ARE SUBJECT TO CHANGE WITHOUT NOTICE AT ANY TIME.
 3. DIMENSIONS ARE IN INCHES [mm].

DWG TITLE

ET9759

CAGE CODE 53919

8TH FLOOR, BUILDING 1, YONGFU SCIENCE AND TECHNOLOGY
 CENTER INDUSTRIAL PARK, NANZHA DISTRICT 5,
 HUMEN, 523900, DONGGUAN, GUANGDONG, CHINA

WEBSITE: www.ebeestock.com
 EMAIL: sales@ebeestock.com



ebeestock

7361

SIZE A

SCALE N/A

CAD FILE 06/07/18