

# 3.5mm Female Precision Connector Threaded Attachment for VNA Test Cable

## REVISIONS

REV.	DESCRIPTION	DATE	APPROVED
A	INITIAL RELEASE	12/04/19	S. SELLIS

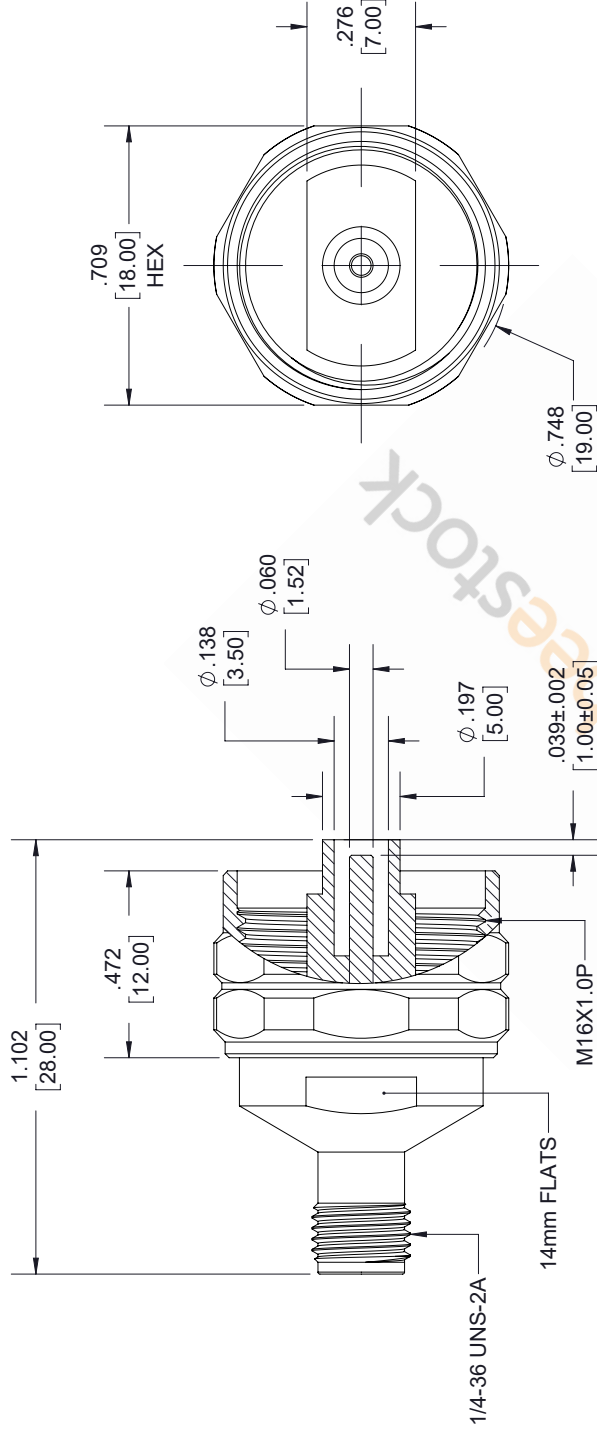

RPC-3.50 FEMALE

RPC-SL MALE

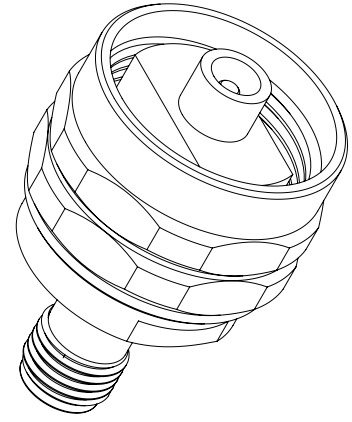

UNLESS OTHERWISE SPECIFIED LEADING DIMENSIONS ARE INCHES DIMENSIONS IN [ ] ARE MILLIMETERS

TOLERANCES:

.X = ±.2 [5.08] FRACTIONS ± 1/32  
 .XX = ±.02 [.51] ANGLES ± 1°  
 .XXX = ±.005 [.13] CABLE LENGTH (L) TOLERANCES:  
 L ≤ 12 [305] = +1 [25] / -0  
 12 [305] < L ≤ 60 [1524] = +2 [51] / -0  
 60 [1524] < L ≤ 120 [3048] = +4 [102] / -0  
 120 [3048] < L ≤ 300 [7620] = +6 [152] / -0  
 300 [7620] < L = +5% / L / -0

ALL DIMENSIONS SHOWN ARE FOR REFERENCE ONLY.



8TH FLOOR, BUILDING 1,  
 YONGFU SCIENCE AND TECHNOLOGY  
 CENTER INDUSTRIAL PARK, WANZHA DISTRICT  
 51 HUMAN 523800, DONGGUAN, GUANGDONG, CHINA  
 WEBSITE: [www.ebeestock.com](http://www.ebeestock.com)  
 EMAIL: [sales@ebeestock.com](mailto:sales@ebeestock.com)

THIRD-ANGLE PROJECTION

THE INFORMATION AND DESIGN IN THIS DOCUMENT IS THE PROPERTY OF EBEESTOCK. ALL RIGHTS RESERVED.

SHEET 1 OF 1

SCALE N/A

REV A

PART NUMBER ET9975

SIZE A

CAGE CODE 53919

DRAWN BY K.DANG

THESE COMMODITIES, TECHNOLOGY OR SOFTWARE WERE EXPORTED FROM THE UNITED STATES IN ACCORDANCE WITH THE EXPORT ADMINISTRATION REGULATIONS. DIVERSION CONTRARY TO U.S. LAW PROHIBITED.