

MATERIALS

BODY	BRASS NICKEL PLATED
CONTACT	SILVER PLATED
INSULATOR	PTFE

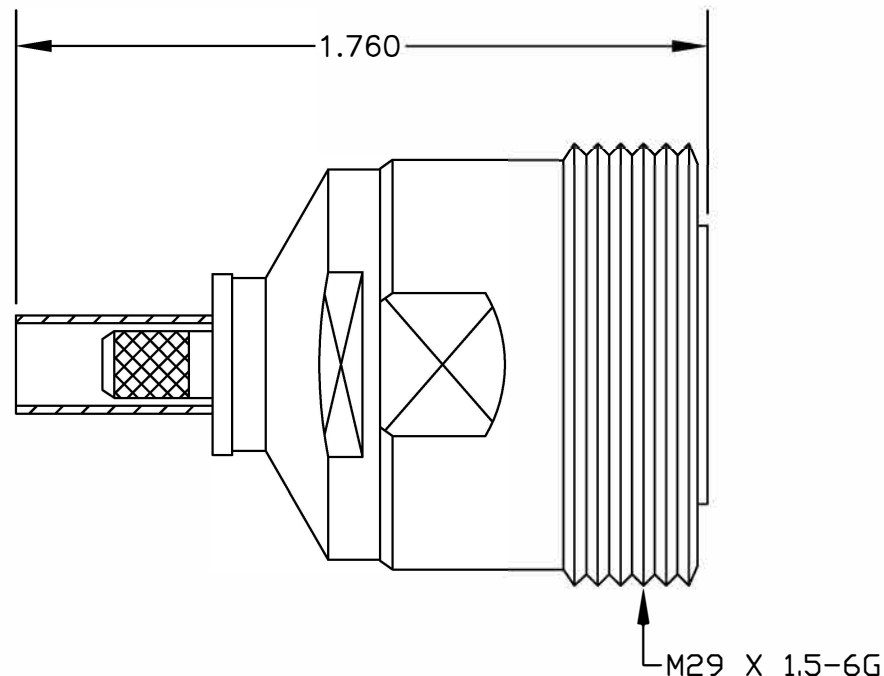

ASSEMBLY PROCEDURES

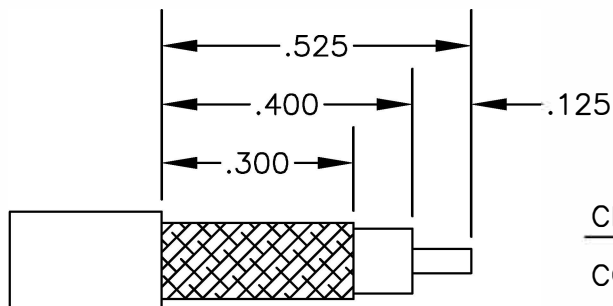

STRIPPING DIMENSIONS

CRIMP SIZE REQUIRED

CONTACT: SOLDER
 FERRULE: .213" HEX CRIMP TOOL



8TH FLOOR, BUILDING 1, YONGFU SCIENCE AND TECHNOLOGY
 CENTER INDUSTRIAL PARK, NANZHA DISTRICT 5,
 HUMEN, 523900, DONGGUAN, GUANGDONG, CHINA

ebeestock

WEBSITE: www.ebeestock.com
 EMAIL: sales@ebeestock.com

ET10031

DES. 7/16" FEMALE, CRIMP ATTACHMENT FOR
 RG58

SIZE A | **FSCM NO. 53919**

CAD FILE 022202

SCALE N/A

127

NOTES:

1. UNLESS OTHERWISE SPECIFIED ALL DIMENSIONS ARE NOMINAL.
2. ALL SPECIFICATIONS ARE SUBJECT TO CHANGE WITHOUT NOTICE AT ANY TIME.