

# 75 Ohm TNC Male Connector Crimp/Solder Attachment for RG59, RG62

REVISIONS			
REV.	DESCRIPTION	DATE	APPROVED
A	PCR PE44166	5/19/2020	S.ELLIS

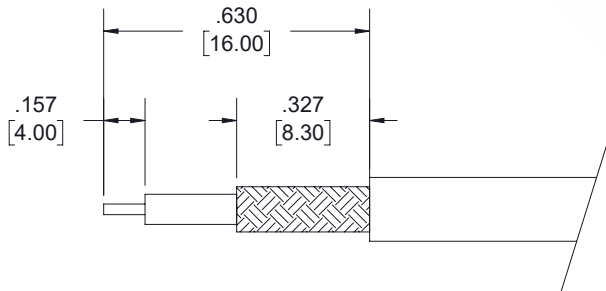
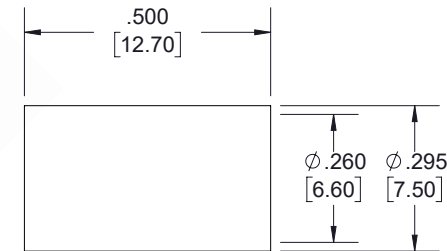
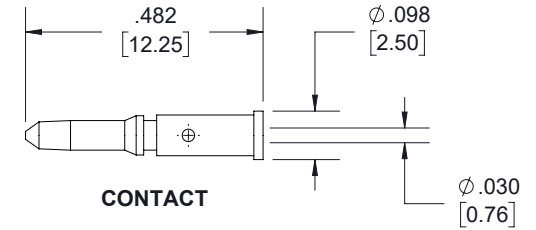
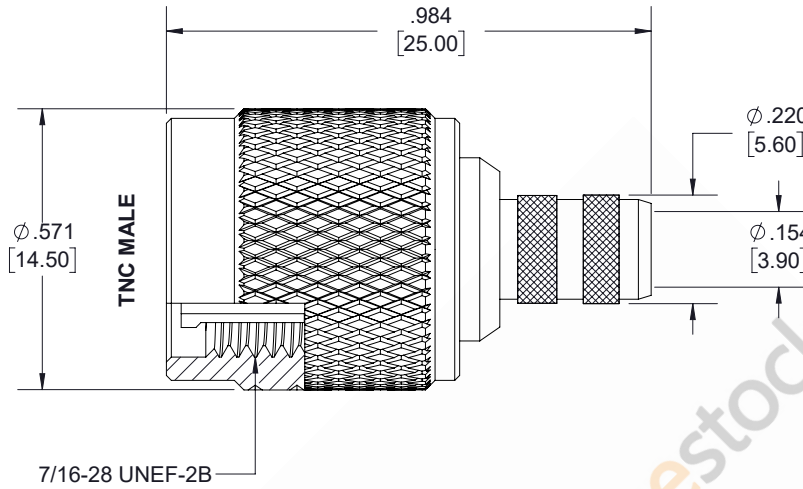
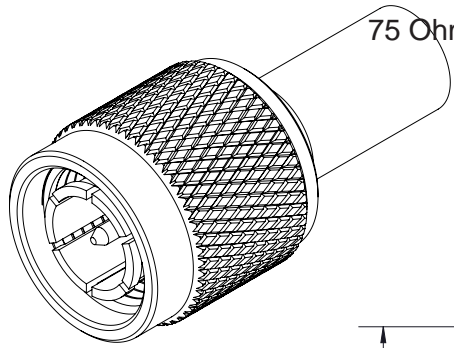

## STRIPPING DIMENSIONS

### NOTES:

- CABLE ATTACHMENT:
  - OUTER: SOLDER.
  - INNER: SOLDER.
- CRIMP SIZE REQUIRED:
  - FERRULE: .255 [6.48] HEX. CRIMP TOOL.
  - CONTACT: .068 [1.73] HEX. CRIMP TOOL.

THESE COMMODITIES, TECHNOLOGY OR SOFTWARE WERE EXPORTED FROM THE UNITED STATES IN ACCORDANCE WITH THE EXPORT ADMINISTRATION REGULATIONS. DIVERSION CONTRARY TO U.S. LAW PROHIBITED.

UNLESS OTHERWISE SPECIFIED LEADING DIMENSIONS ARE INCHES DIMENSIONS IN [ ] ARE MILLIMETERS

#### TOLERANCES:

.X = ±.2 [5.08]	FRACTIONS ± 1/32
.XX = ±.02 [.51]	ANGLES ± 1°
.XXX = ±.005 [.13]	

#### CABLE LENGTH (L) TOLERANCES:

L ≤ 12 [305]	= +1 [25] / -0
12 [305] < L ≤ 60 [1524]	= +2 [51] / -0
60 [1524] < L ≤ 120 [3048]	= +4 [102] / -0
120 [3048] < L ≤ 300 [7620]	= +6 [152] / -0
300 [7620] < L	= +5%L / -0

ALL DIMENSIONS SHOWN ARE FOR REFERENCE ONLY.



8TH FLOOR, BUILDING 1,  
YONGFU SCIENCE AND TECHNOLOGY  
CENTER INDUSTRIAL PARK, NANZHA DISTRICT  
5, HUMAN, 523800, DONGGUAN, GUANGDONG, CHINA

WEBSITE: [www.ebeestock.com](http://www.ebeestock.com)  
EMAIL: [sales@ebeestock.com](mailto:sales@ebeestock.com)

#### THIRD-ANGLE PROJECTION

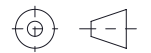

THE INFORMATION AND DESIGN IN THIS DOCUMENT IS THE PROPERTY OF EBEESTOCK. ALL RIGHTS RESERVED.

SHEET 1 OF 1

SCALE N/A

SIZE	CAGE CODE	DRAWN BY	ITEM NO.	REV
A	53919	K.DANG	ET10256	A