

BMA Plug Slide-On Hermetically Sealed Thread-In Mount

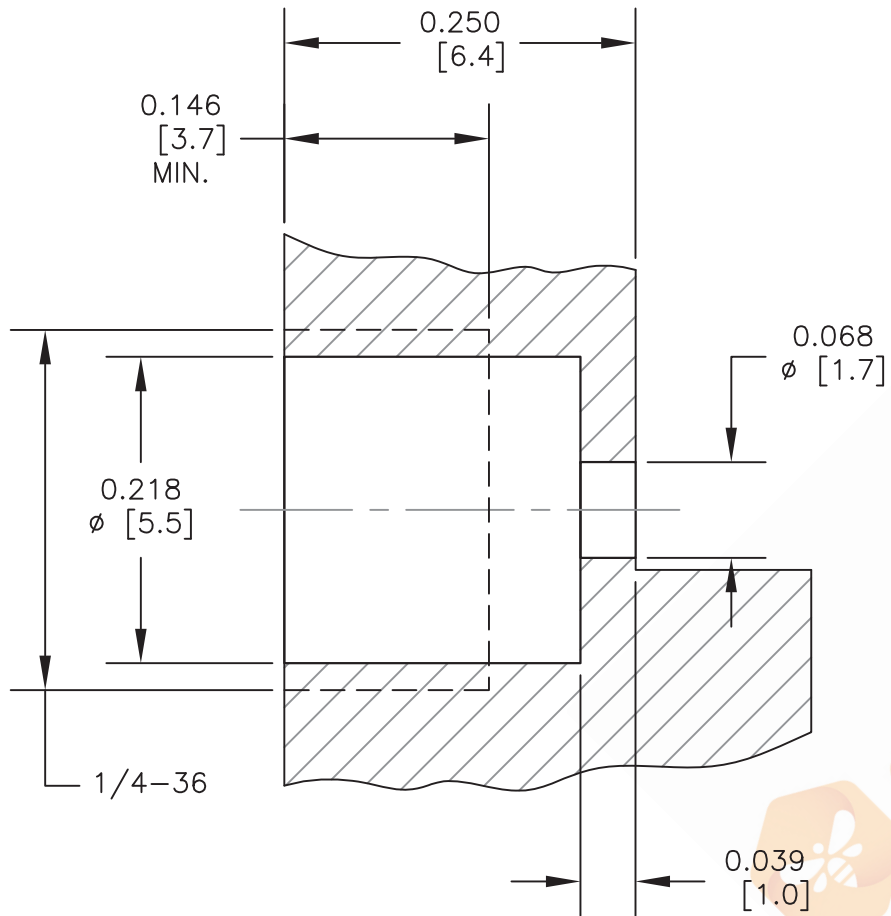

PANEL DRILLING

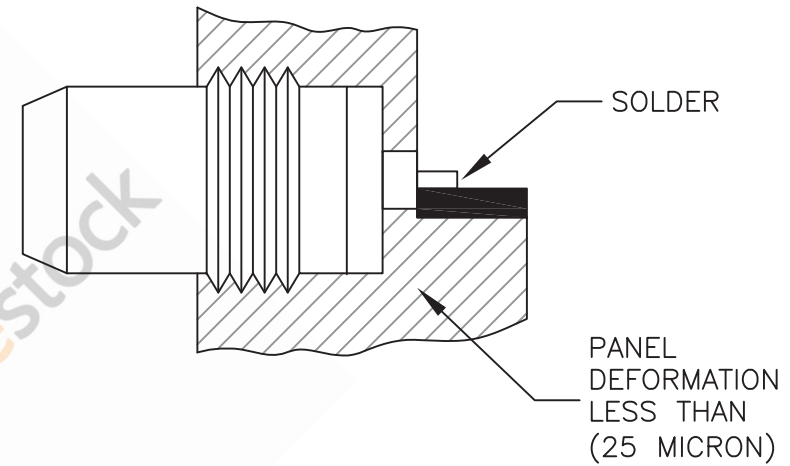

MOUNTING PROCEDURE

1. Assemble metal gasket onto connector.
2. Tighten the connector up to 280 Ncm torque (24.78 Lbs. In)
3. Thus the connection hermeticity is guaranteed at $1 \cdot 10^{-5}$ atm.cm³/sec. Then solder the pin.

STANDARD TOLERANCES

.X	±0.2
.XX	±0.1
.XXX	±0.05

*STANDARD TOLERANCES APPLY ONLY TO DIMENSIONS IN INCHES



8TH FLOOR, BUILDING 1, YONGFU SCIENCE AND TECHNOLOGY
CENTER INDUSTRIAL PARK, NANZHA DISTRICT 5,
HUMEN, 523900, DONGGUAN, GUANGDONG, CHINA

WEBSITE: www.ebeestock.com
EMAIL: sales@ebeestock.com

DWG TITLE

ET10307

NOTES:

1. UNLESS OTHERWISE SPECIFIED ALL DIMENSIONS ARE NOMINAL.
2. ALL SPECIFICATIONS ARE SUBJECT TO CHANGE WITHOUT NOTICE AT ANY TIME.
3. DIMENSIONS ARE IN INCHES [mm].

CAGE CODE 53919

CAD FILE 020917

SCALE N/A

SIZE A

2233