

BNC Male Right Angle Connector Crimp/Solder Attachment for RG59, RG62, RG71

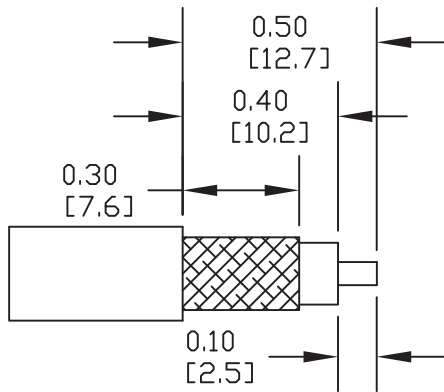

STRIPPING DIMENSIONS

ASSEMBLY PROCEDURES

1. STRIP CABLE AS SHOWN. SLIDE FERRULE OVER CABLE & CRIMP CONTACT TO CENTER CONDUCTOR.
2. INSTALL CABLE INTO BODY. PUSH CABLE FORWARD UNTIL CONTACT IS IN THE CORRECT POSITION.
3. CRIMP FERRULE

CRIMP SIZES REQUIRED

CONTACT: .068" HEX CRIMP TOOL
 FERRULE: .255" HEX CRIMP TOOL

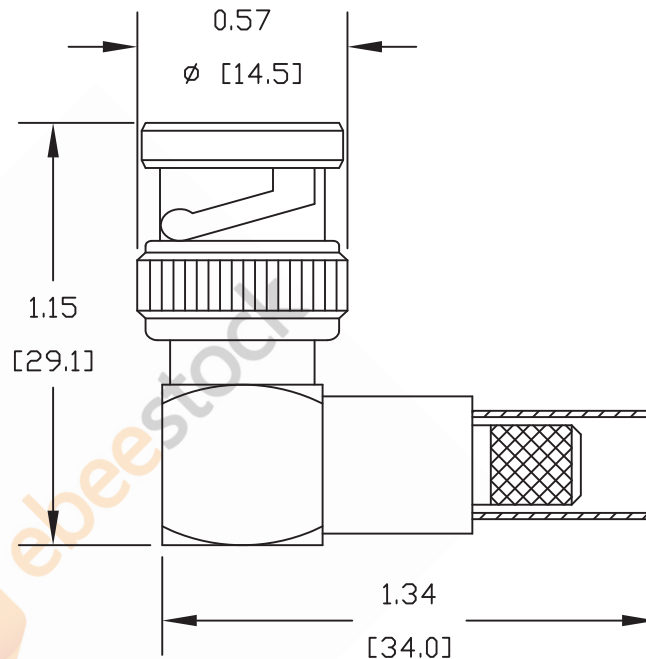

8TH FLOOR, BUILDING 1, YONGFU SCIENCE AND TECHNOLOGY
 CENTER INDUSTRIAL PARK, NANZHA DISTRICT 5,
 HUMEN, 523900, DONGGUAN, GUANGDONG, CHINA

WEBSITE: www.ebeestock.com
 EMAIL: sales@ebeestock.com

DWG TITLE

ET10339

NOTES:

1. UNLESS OTHERWISE SPECIFIED ALL DIMENSIONS ARE NOMINAL.
2. ALL SPECIFICATIONS ARE SUBJECT TO CHANGE WITHOUT NOTICE AT ANY TIME.
3. DIMENSIONS ARE IN INCHES [mm].
4. FITS MIL-C-17 AND EQUIVALENT CABLES.

REV. -

FSCM NO. 53919

CAD FILE 042309

SCALE N/A

SIZE A

147