

BNC Male Right Angle Connector Crimp/Solder
Attachment for RG55, RG141, RG142, RG223, RG400

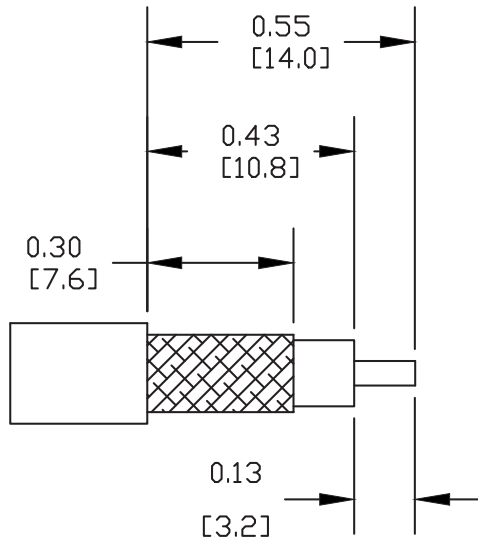

STRIPPING DIMENSIONS

ASSEMBLY PROCEDURES

1. STRIP CABLE AS SHOWN. SLIDE FERRULE OVER CABLE & CRIMP CONTACT TO CENTER CONDUCTOR.
2. INSTALL CABLE INTO BODY. PUSH CABLE FORWARD UNTIL CONTACT IS IN THE CORRECT POSITION.
3. SLIDE FERRULE OVER BRAID & CRIMP.

CRIMP SIZES REQUIRED

CONTACT: .068" HEX CRIMP TOOL
FERRULE: .213" HEX CRIMP TOOL

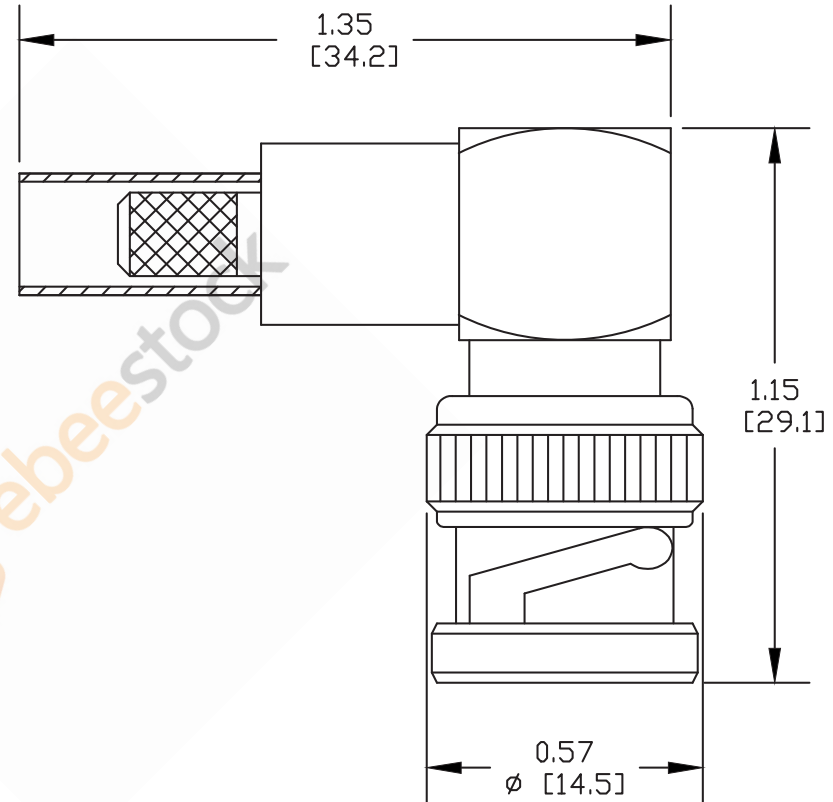

DWG TITLE

ET10358

NOTES:

1. UNLESS OTHERWISE SPECIFIED ALL DIMENSIONS ARE NOMINAL.
2. ALL SPECIFICATIONS ARE SUBJECT TO CHANGE WITHOUT NOTICE AT ANY TIME.
3. DIMENSIONS ARE IN INCHES [mm].
4. FITS MIL-C-17 AND EQUIVALENT CABLES.



8TH FLOOR, BUILDING 1, YONGFU SCIENCE AND TECHNOLOGY
CENTER INDUSTRIAL PARK, NANZHA DISTRICT 5,
HUMEN, 523900, DONGGUAN, GUANGDONG, CHINA

WEBSITE: www.ebeestock.com
EMAIL: sales@ebeestock.com

ebeestock

REV. -

FSCM NO. 53919

CAD FILE 050802

SCALE N/A

SIZE A

127