

BNC Male Right Angle Connector Crimp/Solder Attachment for RG174, RG316, RG188, .100 inch, PE-B100, PE-C100, LMR-100

REVISIONS			
REV.	DESCRIPTION	DATE	APPROVED
B	REVISE STRIPPING DIMENSIONS	11/4/21	SELLIS

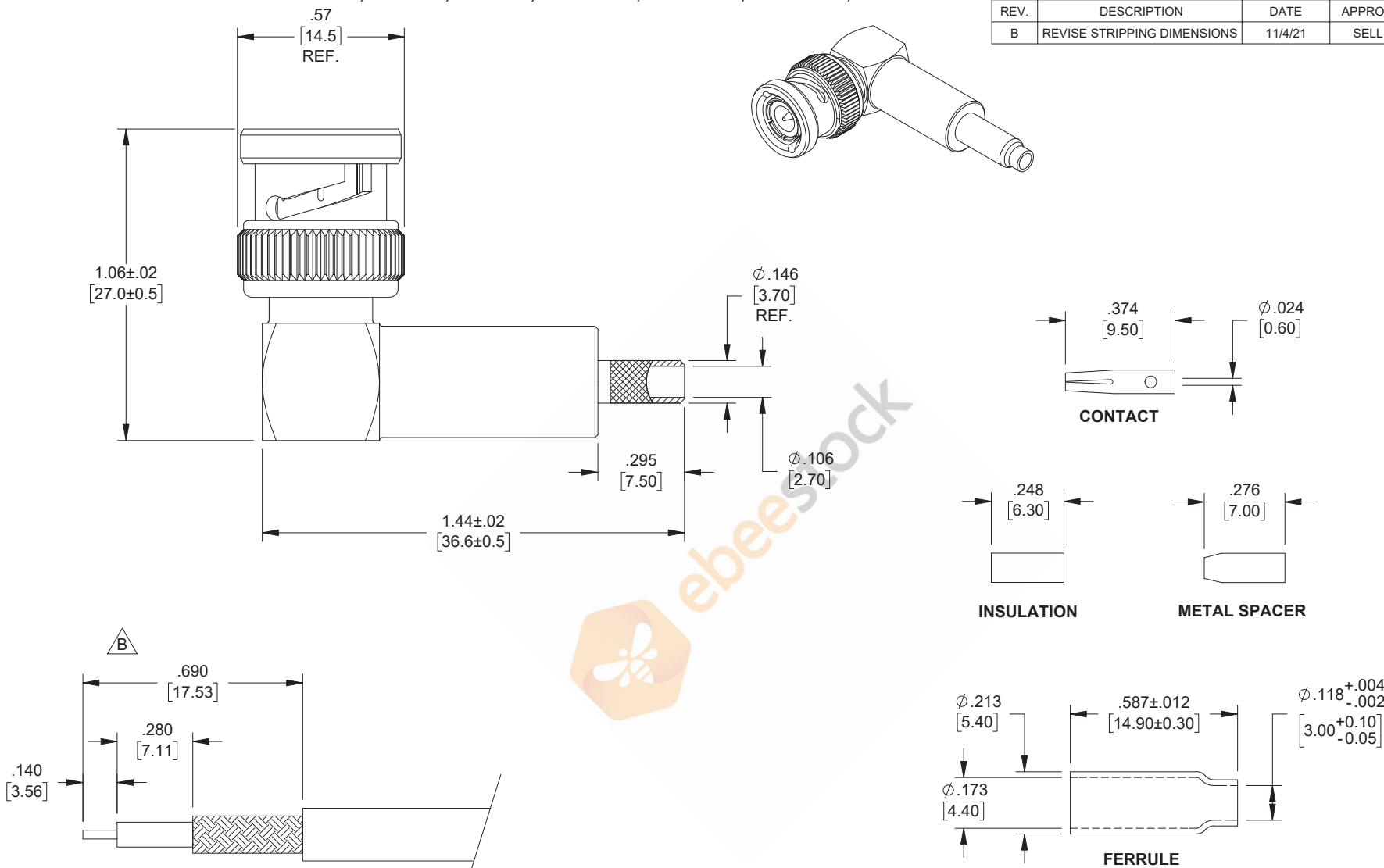

STRIPPING DIMENSIONS

NOTES:

- CABLE ATTACHMENT:
 - OUTER: CRIMP.
 - INNER: SOLDER/CRIMP.
- CRIMP SIZE REQUIRED:
 - FERRULE: .178 [4.52] HEX. CRIMP TOOL
 - CONTACT: .068 [1.73] HEX. CRIMP TOOL.

THESE COMMODITIES, TECHNOLOGY OR SOFTWARE WERE EXPORTED FROM THE UNITED STATES IN ACCORDANCE WITH THE EXPORT ADMINISTRATION REGULATIONS. DIVERSION CONTRARY TO U.S. LAW PROHIBITED.

UNLESS OTHERWISE SPECIFIED
LEADING DIMENSIONS ARE INCHES
DIMENSIONS IN [] ARE MILLIMETERS

TOLERANCES:
 .X = ± .2 [5.08] FRACTIONS ± 1/32
 .XX = ± .02 [.51] ± 1/32
 .XXX = ± .005 [.13] ANGLES ± 1°
CABLE LENGTH (L) TOLERANCES:
 L ≤ 12 [305] = +1 [25] / -0
 12 [305] < L ≤ 60 [1524] = +2 [51] / -0
 60 [1524] < L ≤ 120 [3048] = +4 [102] / -0
 120 [3048] < L ≤ 300 [7620] = +6 [152] / -0
 300 [7620] < L = +5%L / -0

ALL DIMENSIONS SHOWN
ARE FOR REFERENCE ONLY.



8TH FLOOR, BUILDING 1,
YONGFU SCIENCE AND TECHNOLOGY
CENTER INDUSTRIAL PARK, NANZHA DISTRICT
5.HUMEN,523900,DONGGUAN, GUANGDONG, CHINA

WEBSITE: www.ebeestock.com
EMAIL: sales@ebeestock.com

THIRD-ANGLE PROJECTION



THE INFORMATION AND
DESIGN IN THIS DOCUMENT
IS THE PROPERTY OF
EBEESTOCK. ALL RIGHTS
RESERVED.

SHEET 1 OF 1

SCALE N/A

SIZE	CAGE CODE	DRAWN BY	ITEM NO.	REV
A	53919	KDANG	ET10374	B