

BNC Male Connector Crimp/Solder Attachment for LMR-400, PE-C400

REVISIONS			
REV.	DESCRIPTION	DATE	APPROVED
AA	INITIAL RELEASE	12/09/19	S.ELLIS

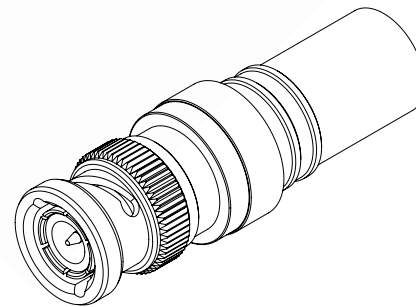
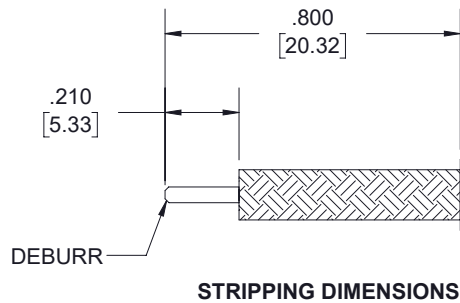
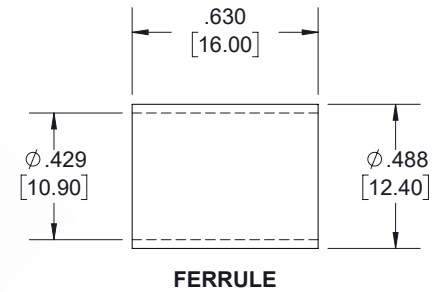
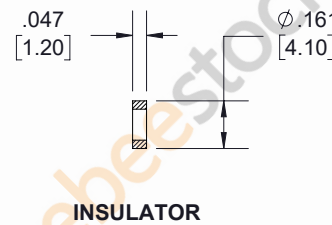
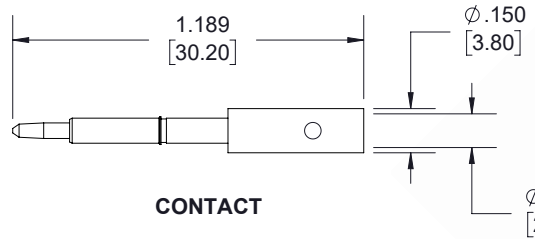
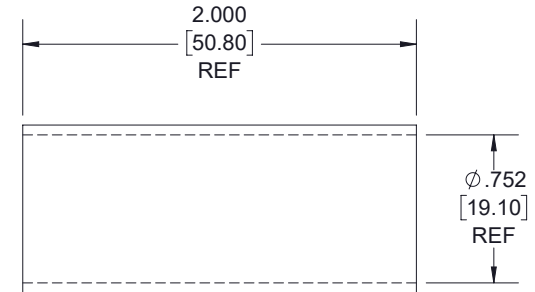
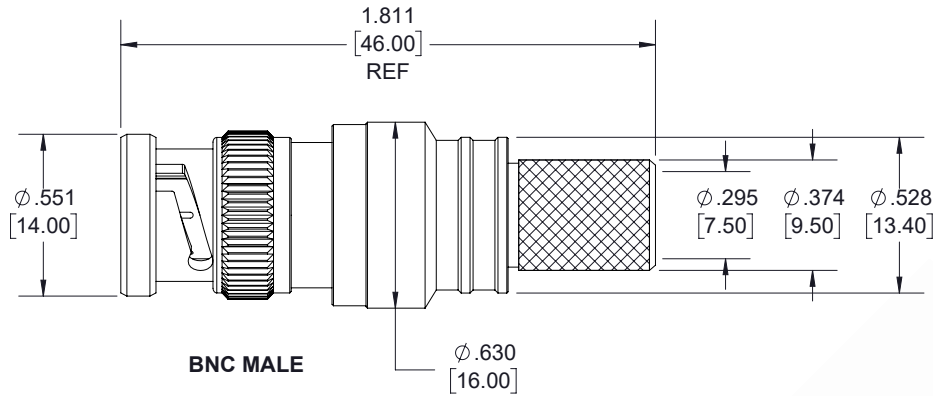

NOTES:

- CABLE ATTACHMENT:
 - OUTER: CRIMP.
 - INNER: SOLDER.
- CRIMP SIZE REQUIRED:
 - FERRULE: .429 [10.90] HEX. CRIMP TOOL.
 - CONTACT: SOLDER.

THESE COMMODITIES, TECHNOLOGY OR SOFTWARE WERE EXPORTED FROM THE UNITED STATES IN ACCORDANCE WITH THE EXPORT ADMINISTRATION REGULATIONS. DIVERSION CONTRARY TO U.S. LAW PROHIBITED.

UNLESS OTHERWISE SPECIFIED LEADING DIMENSIONS ARE INCHES DIMENSIONS IN [] ARE MILLIMETERS

TOLERANCES:

.X = ±.2 [5.08]	FRACTIONS ± 1/32
.XX = ±.02 [51]	ANGLES ± 1°
.XXX = ±.005 [.13]	

CABLE LENGTH (L) TOLERANCES:

L ≤ 12 [305]	= +1 [25] / -0
12 [305] < L ≤ 60 [1524]	= +2 [51] / -0
60 [1524] < L ≤ 120 [3048]	= +4 [102] / -0
120 [3048] < L ≤ 300 [7620]	= +6 [152] / -0
300 [7620] < L	= +5%L / -0

ALL DIMENSIONS SHOWN ARE FOR REFERENCE ONLY.



8TH FLOOR, BUILDING 1,
YONGFU SCIENCE AND TECHNOLOGY
CENTER INDUSTRIAL PARK, NANZHA DISTRICT
5, HUMAN 523800, DONGGUAN, GUANGDONG, CHINA

WEBSITE: www.ebeestock.com
EMAIL: sales@ebeestock.com

THIRD-ANGLE PROJECTION

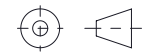

THE INFORMATION AND DESIGN IN THIS DOCUMENT IS THE PROPERTY OF EBEESTOCK. ALL RIGHTS RESERVED.

SHEET 1 OF 1

SCALE N/A

SIZE	CAGE CODE	DRAWN BY	PART NUMBER	REV
A	53919	K.DANG	ET10458	A