

BNC Twinax Plug Connector Clamp/Solder Attachment for RG108, 78 Ohm
Twinax

ASSEMBLY PROCEDURES

1. SLIDE CLAMP NUT (1), WASHER (2) & GASKET (3) OVER CABLE. STRIP CABLE TO DIMENSION SHOWN. DO NOT NICK BRAID & DIELECTRIC. COMB OUT BRAID. TAPER END OF BRAID TO PERMIT ASSEMBLY OF BRAID CLAMP (4). SLIDE BRAID CLAMP (4) OVER BRAID & BUTT AGAINST JACKET. FORM BRAID OVER CLAMP NUT (4). TRIM BRAID FLUSH WITH SHOULDER OF BRAID CLAMP (4).

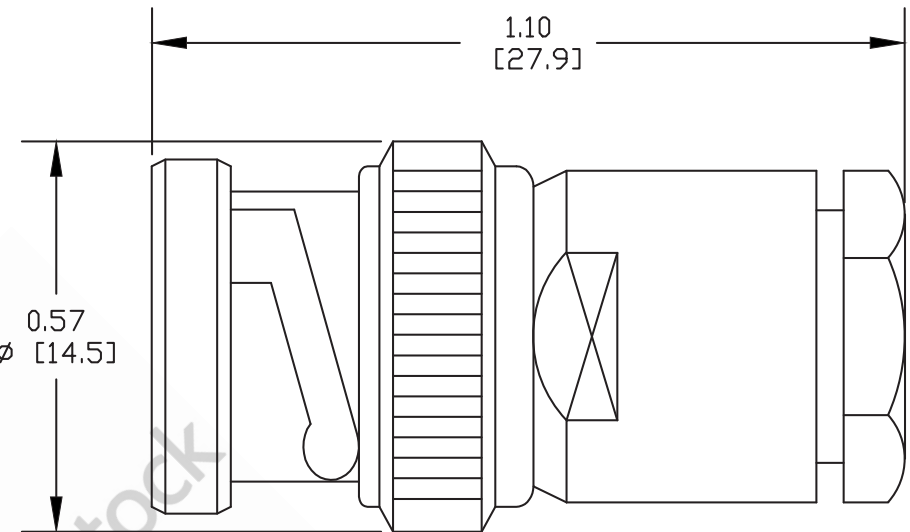
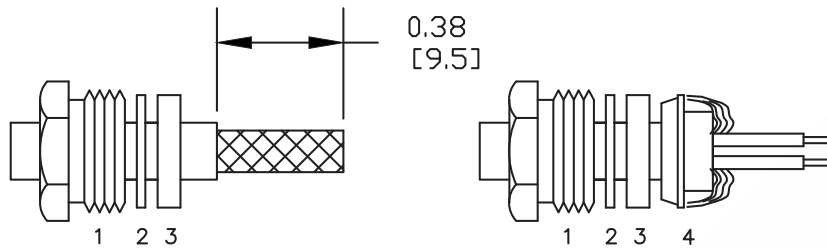

2. STRIP CABLE TO DIMENSION SHOWN. SLIDE SMALL WASHER (5) REAR INSULATOR (6) OVER DIELECTRICS. SOLDER CONTACTS (7) TO CENTER CONDUCTOR THROUGH HOLE IN CONTACT. CLEAN EXCESS SOLDER. SLIDE FRONT INSULATOR (8) OVER CONTACTS. SLIDE ASSEMBLY FORWARD INTO BODY & TIGHTEN.

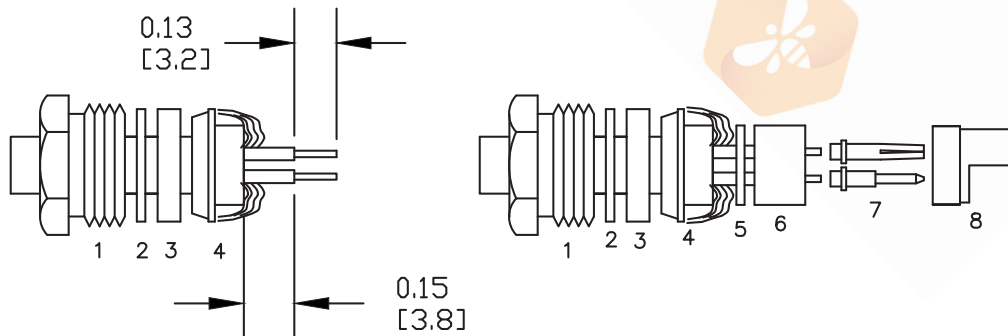

* WHEN SOLDERING CONTACTS MAKE SURE SAME SEX IS ON BOTH ENDS OF WIRE IDENTIFIED BY THE BARE COPPER WIRE.



8TH FLOOR, BUILDING 1, YONGFU SCIENCE AND TECHNOLOGY
CENTER INDUSTRIAL PARK, NANZHA DISTRICT 5,
HUMEN, 523900, DONGGUAN, GUANGDONG, CHINA

WEBSITE: www.ebeestock.com
EMAIL: sales@ebeestock.com

ebeestock

DWG TITLE

ET10461

NOTES:

1. UNLESS OTHERWISE SPECIFIED ALL DIMENSIONS ARE NOMINAL.
2. ALL SPECIFICATIONS ARE SUBJECT TO CHANGE WITHOUT NOTICE AT ANY TIME.
3. DIMENSIONS ARE IN INCHES (mm).
4. FITS MIL-C-17 AND EQUIVALENT CABLES.

REV. -

FSCM NO. 53919

CAD FILE 123005

SCALE N/A

SIZE A

127