

MATERIALS

BODY	BRASS GOLD PLATED
CONTACT	GOLD PLATED
INSULATOR	PTFE

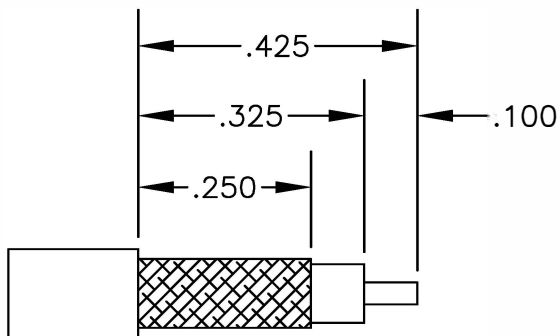
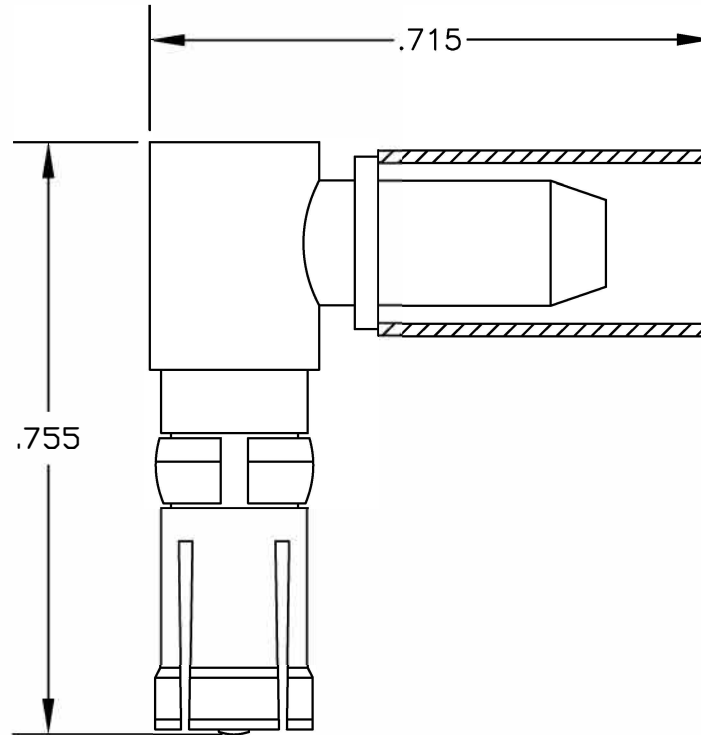

STRIPPING DIMENSIONS

ASSEMBLY PROCEDURES

1. STRIP CABLE AS SHOWN & SLIDE FERRULE OVER CABLE.
2. INSTALL CABLE INTO BODY OF CONNECTOR AND SOFT SOLDER CENTER CONDUCTOR IN PLACE.
3. CRIMP FERRULE & SOLDER CAP IN PLACE.

CRIMP SIZE REQUIRED

FERRULE: .213" HEX CRIMP TOOL



8TH FLOOR, BUILDING 1, YONGFU SCIENCE AND TECHNOLOGY CENTER INDUSTRIAL PARK, NANZHA DISTRICT 5, HUMEN, 523900, DONGGUAN, GUANGDONG, CHINA

ebeestock
DWG TITLE

WEBSITE: www.ebeestock.com
EMAIL: sales@ebeestock.com

ET10515

SIZE A | **FSCM NO. 53919**

DES. D SUBMINIATURE, RIGHT ANGLE, RECEPTACLE, CRIMP ATTACHMENT FOR RG180 & RG195

CAD FILE 061002

SCALE N/A

127

NOTES:

1. UNLESS OTHERWISE SPECIFIED ALL DIMENSIONS ARE NOMINAL.
2. ALL SPECIFICATIONS ARE SUBJECT TO CHANGE WITHOUT NOTICE AT ANY TIME.