

MATERIALS

BODY	BRASS GOLD PLATED
CONTACT	GOLD PLATED
INSULATOR	PTFE

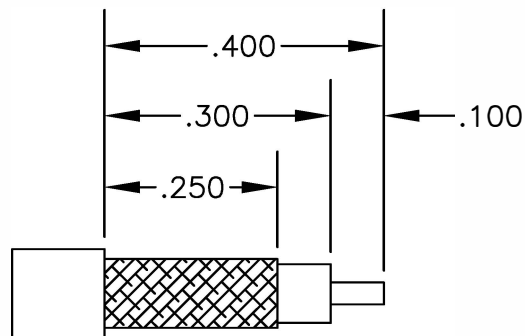
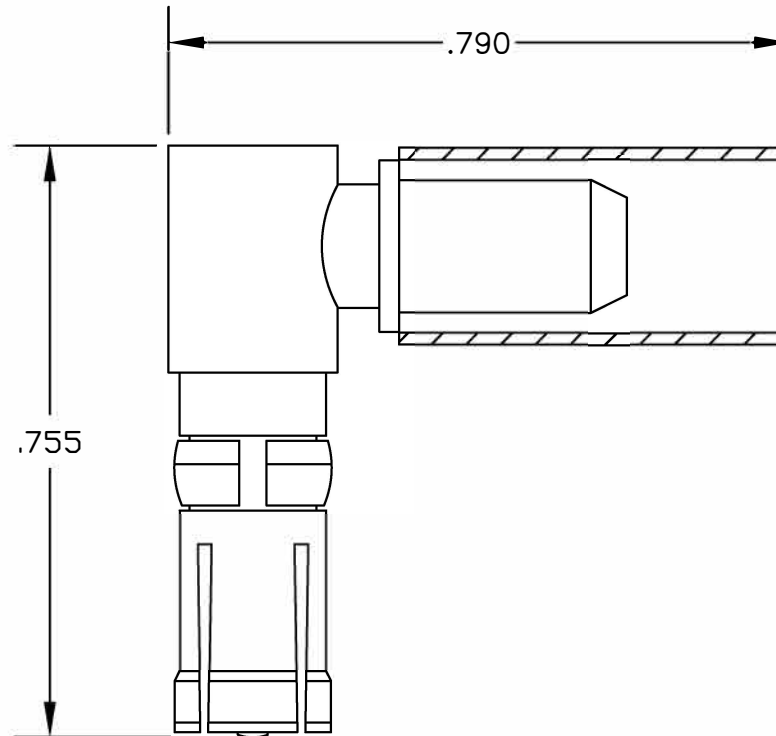

STRIPPING DIMENSIONS

ASSEMBLY PROCEDURES

1. STRIP CABLE AS SHOWN & SLIDE FERRULE OVER CABLE.
2. INSTALL CABLE INTO BODY OF CONNECTOR AND SOFT SOLDER CENTER CONDUCTOR IN PLACE.
3. SOLDER FERRULE & CAP IN PLACE.



8TH FLOOR, BUILDING 1, YONGFU SCIENCE AND TECHNOLOGY
CENTER INDUSTRIAL PARK, NANZHA DISTRICT 5,
HUMEN, 523900, DONGGUAN, GUANGDONG, CHINA

ebeestock
DWG TITLE

WEBSITE: www.ebeestock.com
EMAIL: sales@ebeestock.com

ET10532

SIZE A | **FSCMNO. 53919**

DES. D SUBMINIATURE RECEPTACLE RIGHT
ANGLE, SOLDER ATTACHMENT FOR RG58,
RG142, RG223 & RG400

CAD FILE 061102 SCALE N/A 127

NOTES:

1. UNLESS OTHERWISE SPECIFIED ALL DIMENSIONS ARE NOMINAL.
2. ALL SPECIFICATIONS ARE SUBJECT TO CHANGE WITHOUT NOTICE AT ANY TIME.