

75 Ohm F Male Connector Crimp/Solder Attachment for PE-B159, 1855A, Mini 59

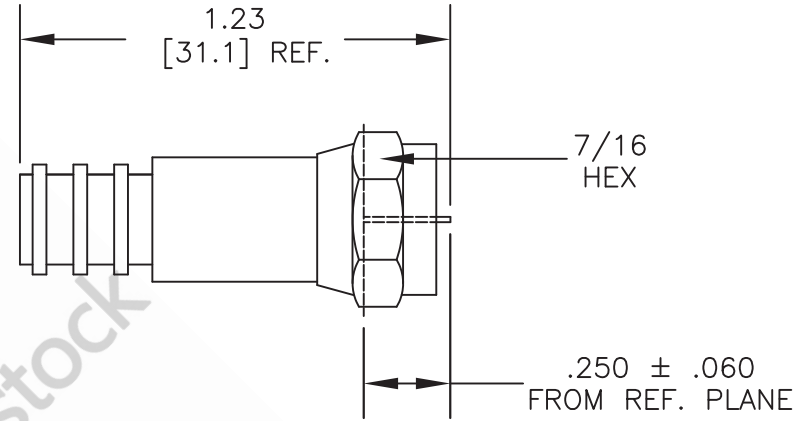
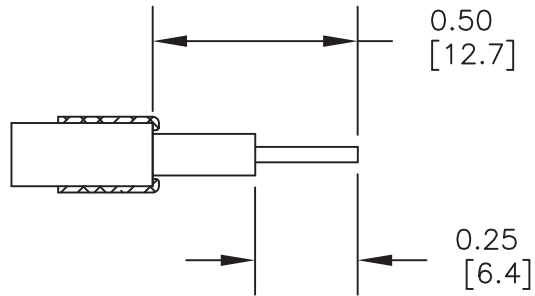

STRIPPING DIMENSIONS

ASSEMBLY PROCEDURES

1. STRIP CABLE AS SHOWN [FOIL SHOULD REMAIN ON DIELECTRIC].
2. FOLD BRAID BACK OVER JACKET.
3. INSERT PREPARED CABLE INTO CONNECTOR. PUSH CABLE FORWARD INTO CONNECTOR WHILE SLIGHTLY TWISTING CONNECTOR AND CRIMP.

CRIMP SIZE REQUIRED

FERRULE: .255" HEX CRIMP TOOL



8TH FLOOR, BUILDING 1, YONGFU SCIENCE AND TECHNOLOGY
CENTER INDUSTRIAL PARK, NANZHA DISTRICT 5,
HUMEN, 523900, DONGGUAN, GUANGDONG, CHINA

WEBSITE: www.ebeestock.com
EMAIL: sales@ebeestock.com

DWG TITLE

ET10559

NOTES:

1. UNLESS OTHERWISE SPECIFIED ALL DIMENSIONS ARE NOMINAL.
2. ALL SPECIFICATIONS ARE SUBJECT TO CHANGE WITHOUT NOTICE AT ANY TIME.
3. DIMENSIONS ARE IN INCHES [mm].
4. FITS MIL-C-17 AND EQUIVALENT CABLES.

FSCM NO. 53919

CAD FILE 050514

SCALE N/A

SIZE A

2233