

MHV Male Connector Clamp/Solder Attachment for RG58, RG55,

ASSEMBLY PROCEDURES RG141, RG142, RG223, RG400, RG303, PE-C195, PE-P195, LMR-195 REF.

1. SLIDE CLAMP NUT (1), WASHER (2) & GASKET (3) OVER CABLE AS SHOWN.

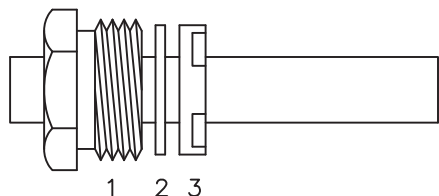

2. TRIM PER DIMENSIONS.

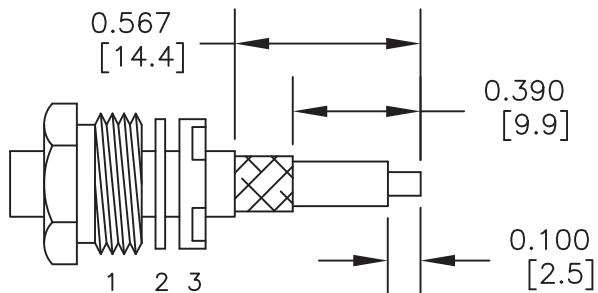

3. a) SLIDE BRAID CLAMP OVER BRAID UNTIL IT STOPS ON CABLE JACKET.
b) FLAIR BRAID AS SHOWN.

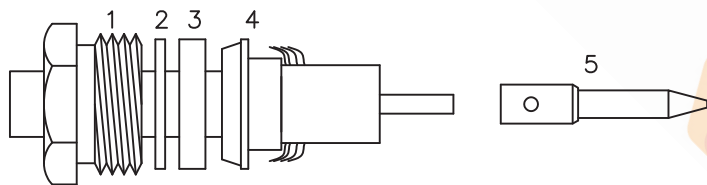

4. INSTALL CONTACT BY SOLDERING TO CABLE CENTER CONDUCTOR LEAVING NO GAPS (5).

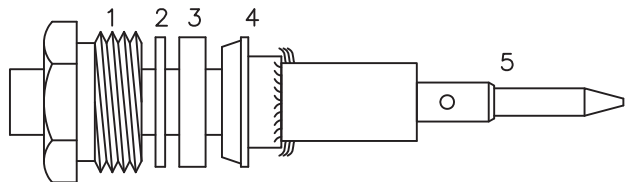

5. REMOVE EXCESS SOLDER. INSERT ASSEMBLY INTO CONNECTOR BODY AND TIGHTEN NUT.

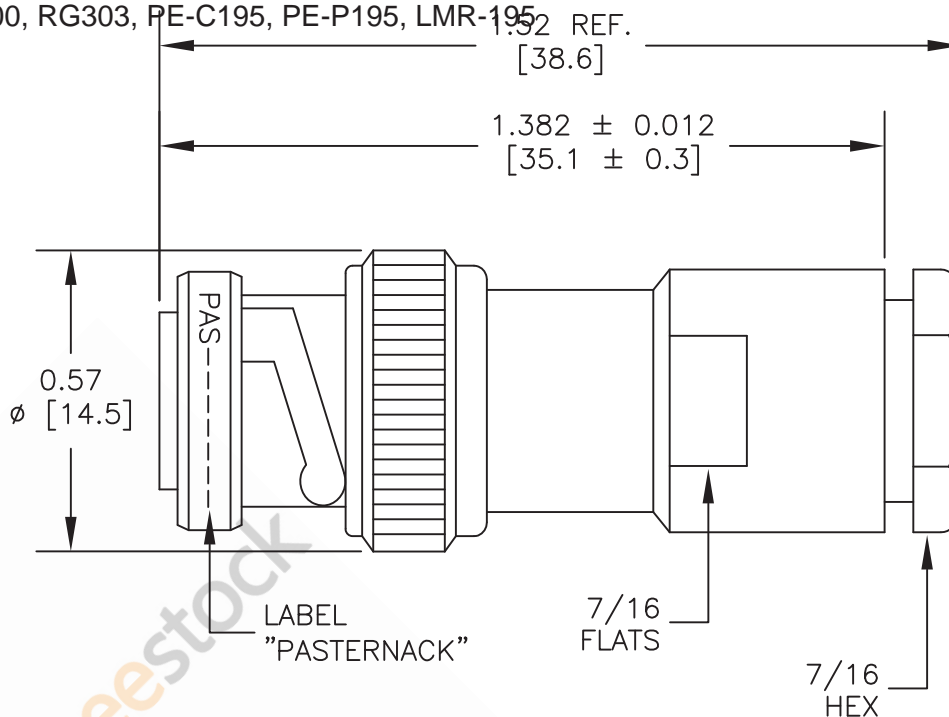

STANDARD TOLERANCES	
.X	±0.2
.XX	±0.1
.XXX	±0.05

*STANDARD TOLERANCES APPLY ONLY TO DIMENSIONS IN INCHES



8TH FLOOR, BUILDING 1, YONGFU SCIENCE AND TECHNOLOGY CENTER INDUSTRIAL PARK, NANZHA DISTRICT 5, HUMEN, 523900, DONGGUAN, GUANGDONG, CHINA

WEBSITE: www.ebeestock.com
EMAIL: sales@ebeestock.com

DWG TITLE

ET10704

NOTES:

- UNLESS OTHERWISE SPECIFIED ALL DIMENSIONS ARE NOMINAL.
- ALL SPECIFICATIONS ARE SUBJECT TO CHANGE WITHOUT NOTICE AT ANY TIME.
- DIMENSIONS ARE IN INCHES [mm].

FSCM NO. 53919

CAD FILE 050216

SCALE N/A

SIZE A

3045