

MATERIALS	
BODY	BRASS NICKEL PLATED
CONTACT	GOLD PLATED
INSULATOR	PTFE

MOUNTING HOLE

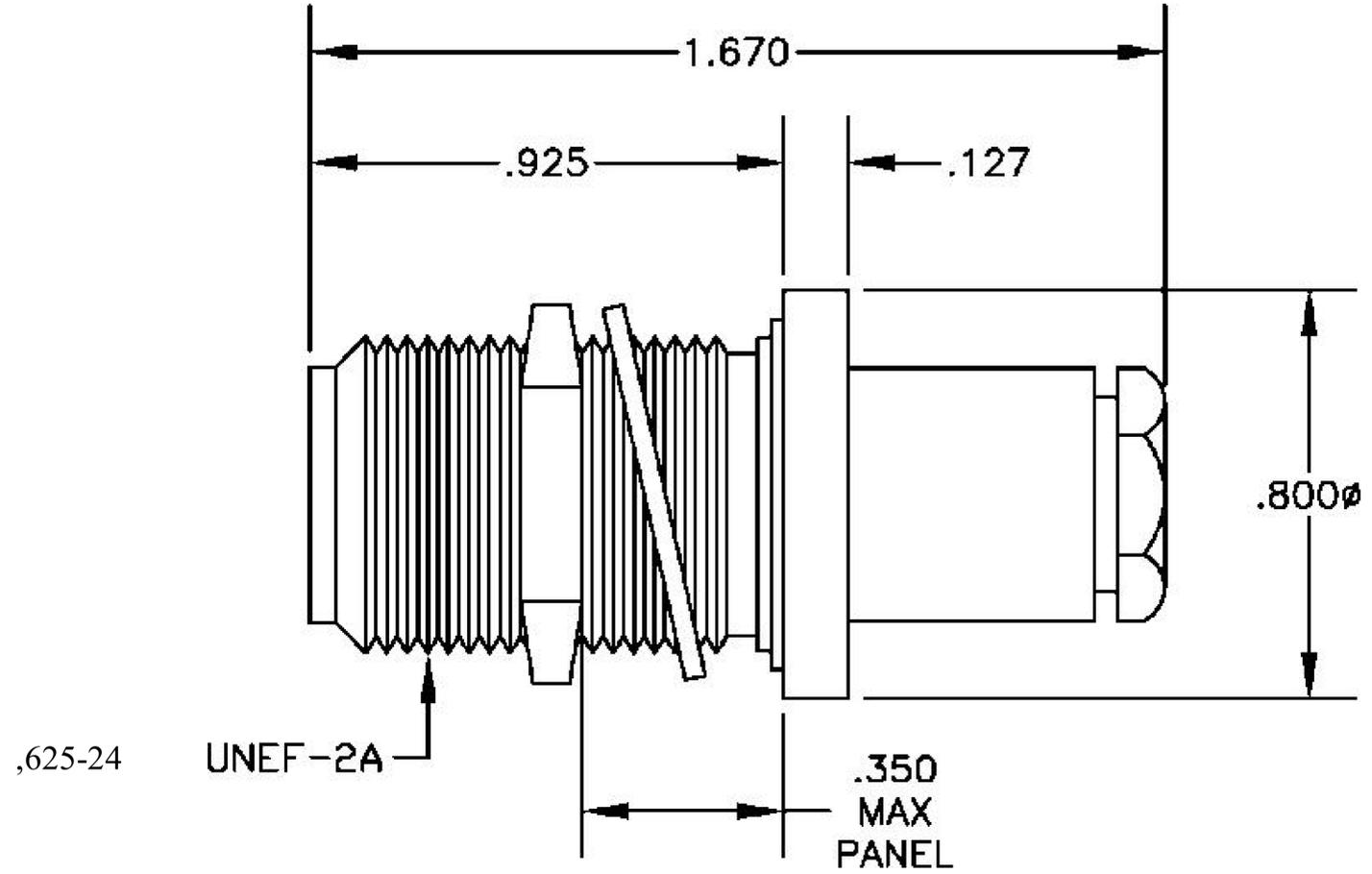
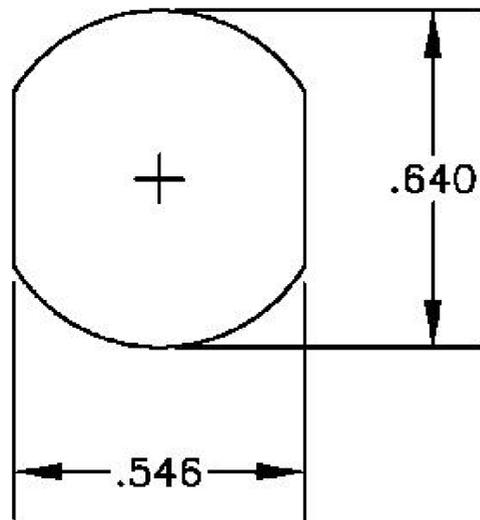

ASSEMBLY PROCEDURES

1. SLIDE CUMMP NUT (1), WASHER (2) & GASKET (3) OVER CABLE. STRIP CABLE AS SHOWN. DO NOT NICK BRAID WHILE CUTTING JACKET. TAPER END OF BRAID TO PERMIT ASSEMBLY OF SEAT AGAINST CABLE. BRAID CLAMP (4). SLIDE BRAID CU\MP (4) OVER BRAID &

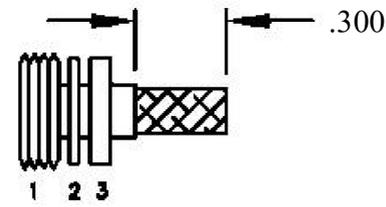

2. FORM BRAID OVER CLAMP NUT (4). TRIM BRAID BACK TO SHOULDER. CUT DIELECTRIC & CENTER CONDUCTOR TO DIMENSION SHOWN. DO NOT NICK CENTER CONDUCTOR. SOLDER CONTACT TO CENTER CONDUCTOR. REMOVE EXCESS SOLDER. DO NOT OVER HEAT DIELECTRIC. INSERT CABLE ASSEMBLY INTO BODY & TIGHTEN.

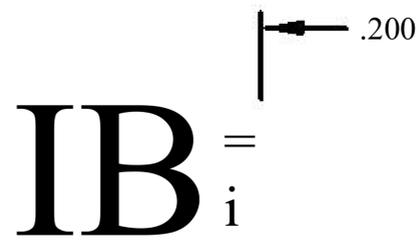

NOTE: INSERT PTFE BEFORE CONTACT. WITH URGE OPEN END SLIDING OVER CENTER CONDUCTOR & DIELECTRIC.



8th Floor, Building 1, Yongfu Science and Technology Center Industrial Park, Nanzha District 5, Humen,523900, Dongguan, Guangdong, China.

Website: [www.ebeestock.com](http://www.ebeestock.com)  
Email: [sales@ebeestock.com](mailto:sales@ebeestock.com)

COAXIAL & FIBER OPTICS

DWG TITLE	ET10899	DES_	n-female-bulkhead-connector-clamp-solder-attachment-for-rg174-rg316-rg188-640-inch-dd-hole-0010899
-----------	---------	------	--

SIZE A | FSCM NO. 53919 | CAD FILE 073102 | SCALE N/A | 127

- NOTES:
- UNLESS OTHERWISE SPECIFIED ALL DIMENSIONS ARE NOMINAL.
  - ALL SPECIFICATIONS ARE SUBJECT TO CHANGE WITHOUT NOTICE AT ANY TIME.