

MATERIALS	
BODY	BRASS NICKEL PLATED
CONTACT	GOLD PLATED
INSULATOR	PTFE
FERRULE	GOLD PLATED

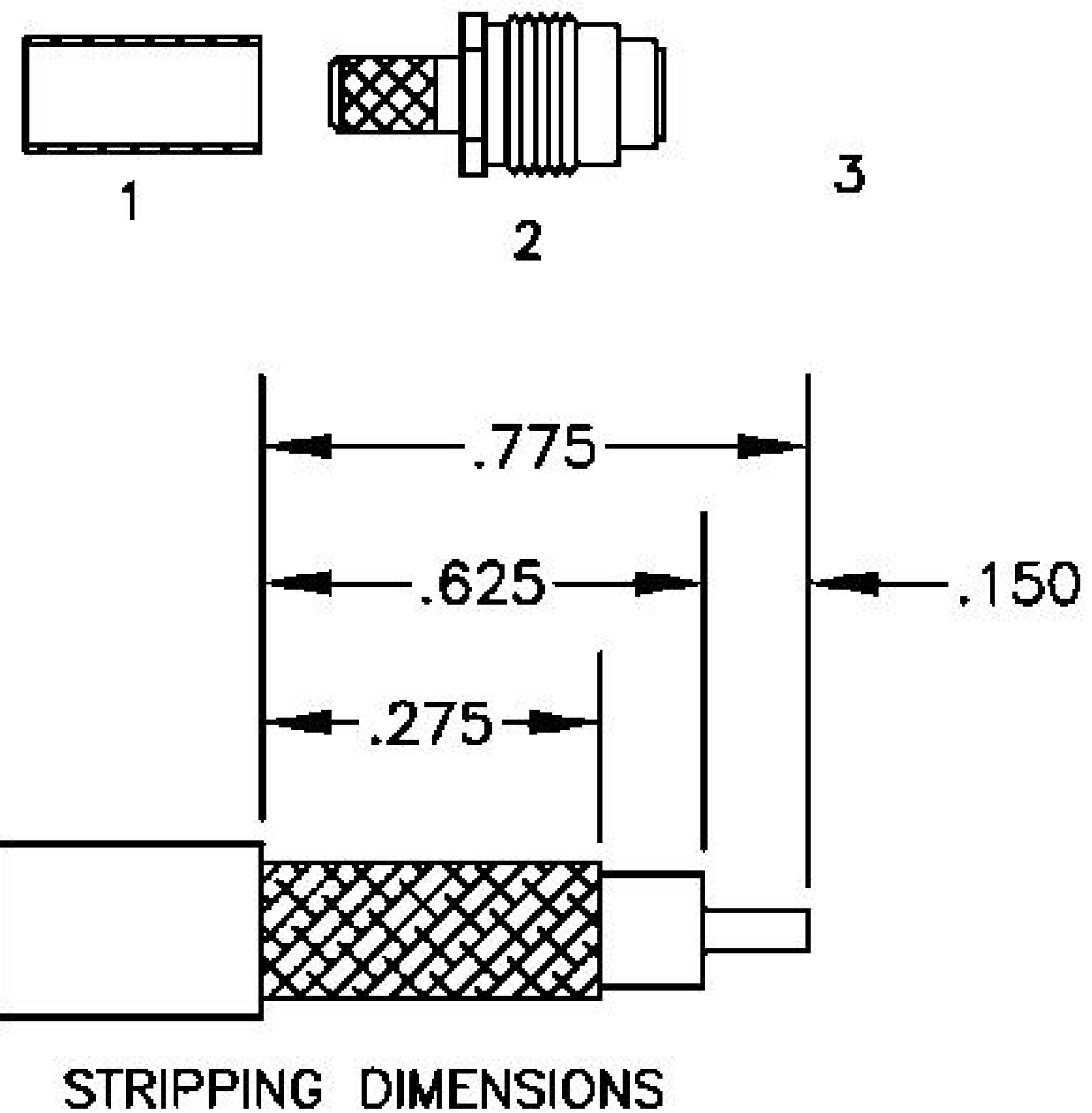

ASSEMBLY PROCEDURES

1. STRIP CABLE AS SHOWN. DO NOT NICK CENTER CONDUCTOR. TIN CENTER CONDUCTOR.
2. SLIDE FERRULE (1) OVER CABLE. FLAIR BRAID & SLIDE WEDGE ASSEMBLY (2) UNDER BRAID WITH CENTER CONDUCTOR PROTRUDING THROUGH HOLE IN INSULATOR. SLIDE FERRULE (1) OVER BRAID & AGAINST CLAMP NUT (2). SOLDER FERRULE TO BRAID.
3. SOLDER CONTACT (3) TO CENTER CONDUCTOR. CLEAN, INSERT CABLE ASSEMBLY INTO BODY & TIGHTEN.

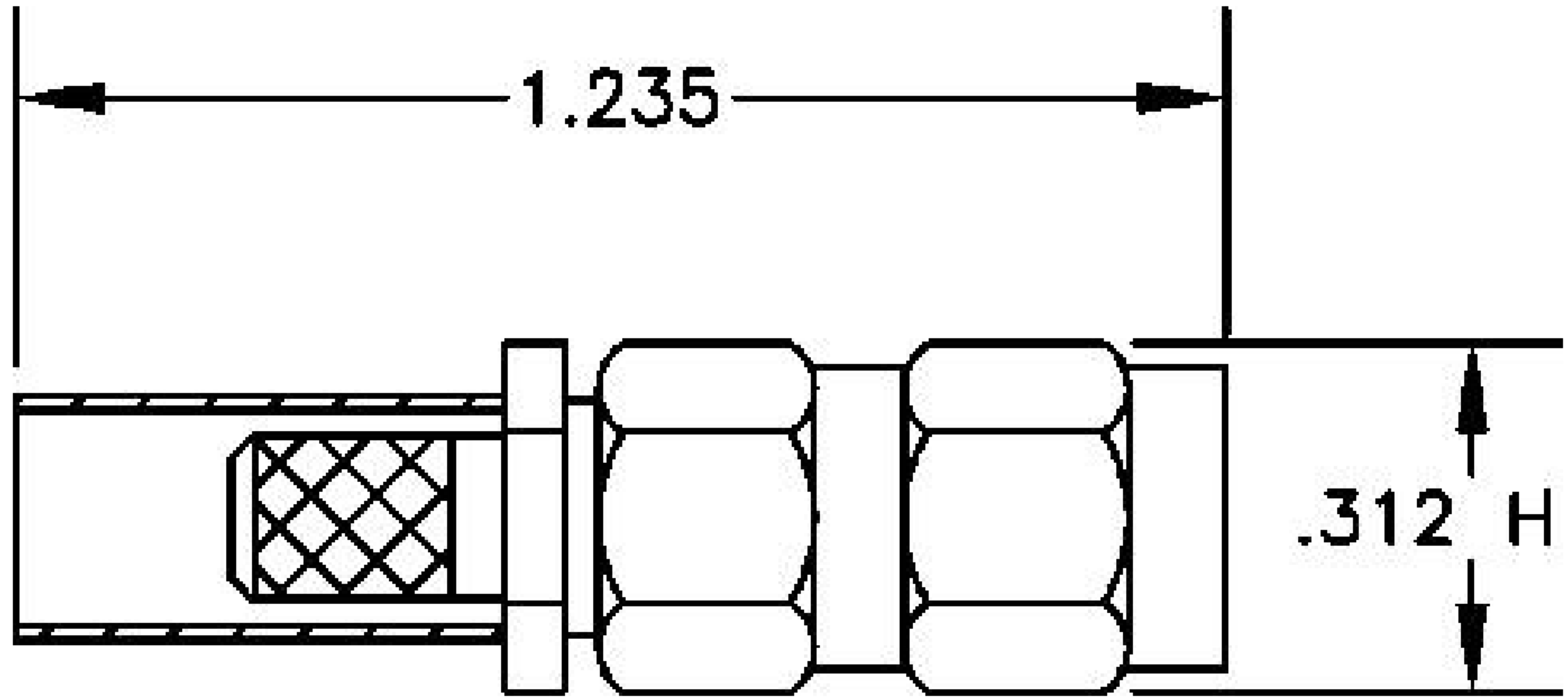

8th Floor, Building 1, Yongfu Science and Technology Center Industrial Park, Nanzha District 5, Humen, 523900, Dongguan, Guangdong, China.

Website: www.ebeestock.com
 Email: sales@ebeestock.com

COAXIAL & FIBER OPTICS

DWG TITLE ET11417	DES_ sma-male-connector-solder-solder-captive-contact-attachment-for-rg58-r g55-rg142-rg223-rg400-0011417
----------------------	---

SIZE A | **FSCM NO. 53919** | CAD FILE 073102 | SCALE N/A | 127

- NOTES:
1. UNLESS OTHERWISE SPECIFIED ALL DIMENSIONS ARE NOMINAL.
 2. ALL SPECIFICATIONS ARE SUBJECT TO CHANGE WITHOUT NOTICE AT ANY TIME.