

MATERIALS	
BODY	BRASS NICKEL PLATED
CONTACT	GOLD PLATED
INSULATOR	PTFE
FERRULE	GOLD PLATED

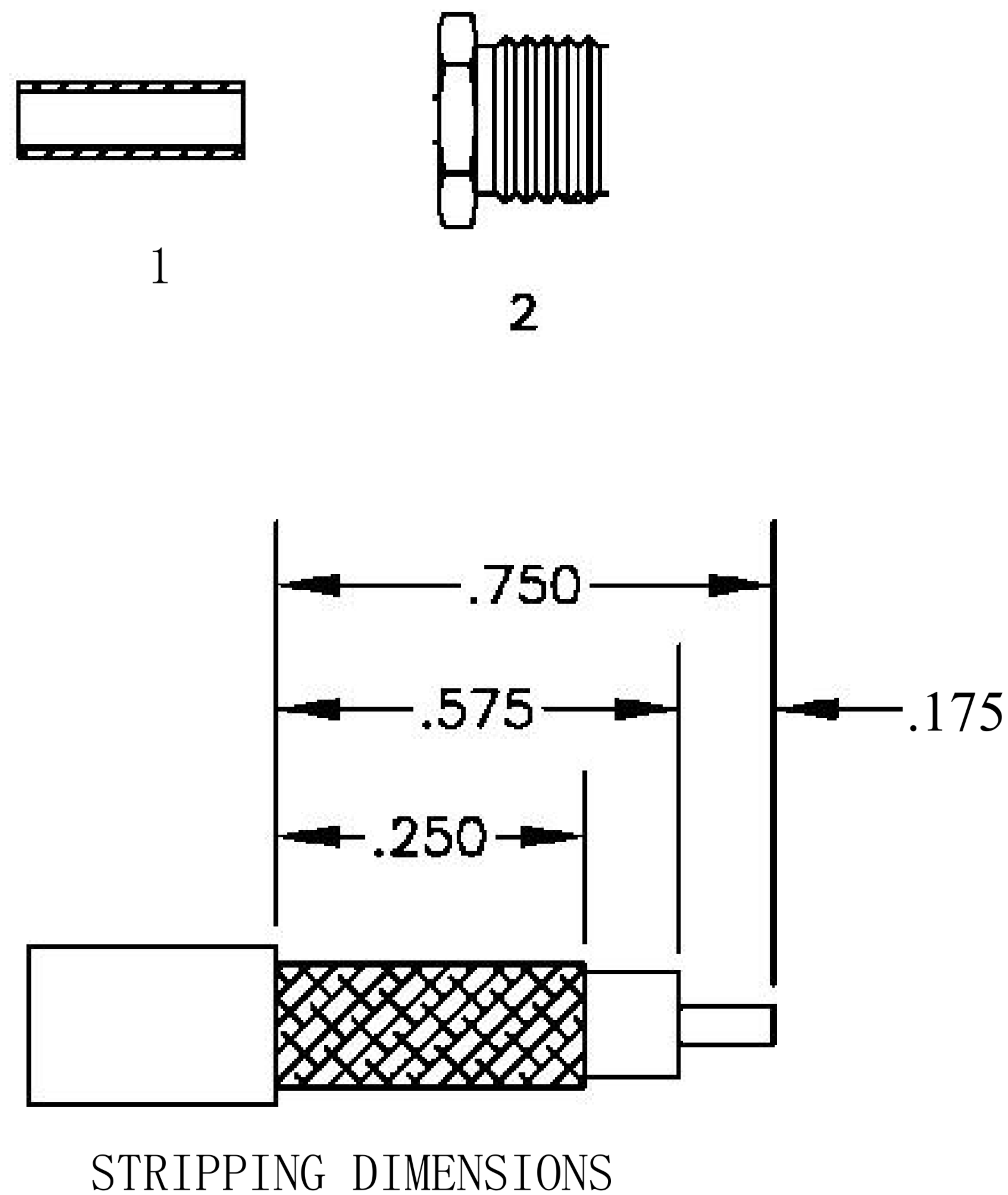

ASSEMBLY PROCEDURES

1. SLIDE FERRULE (1) OVER CABLE. STRIP CABLE AS SHOWN. TIN CENTER CONDUCTOR.
2. FLAIR BRAID & INSERT EXTENSION (2), UNDER BRAID. WITH CENTER CONDUCTOR PROTRUDING THROUGH HOLE IN EXTENSION.
3. SOLDER CONTACT (3) TO CENTER CONDUCTOR. SLIDE FERRULE (1) OVER BRAID & AGAINST CU\MP NUT. SOLDER FERRULE (1) TO BRAID. INSTALL CABLE ASSEMBLY INTO BODY & TIGHTEN.

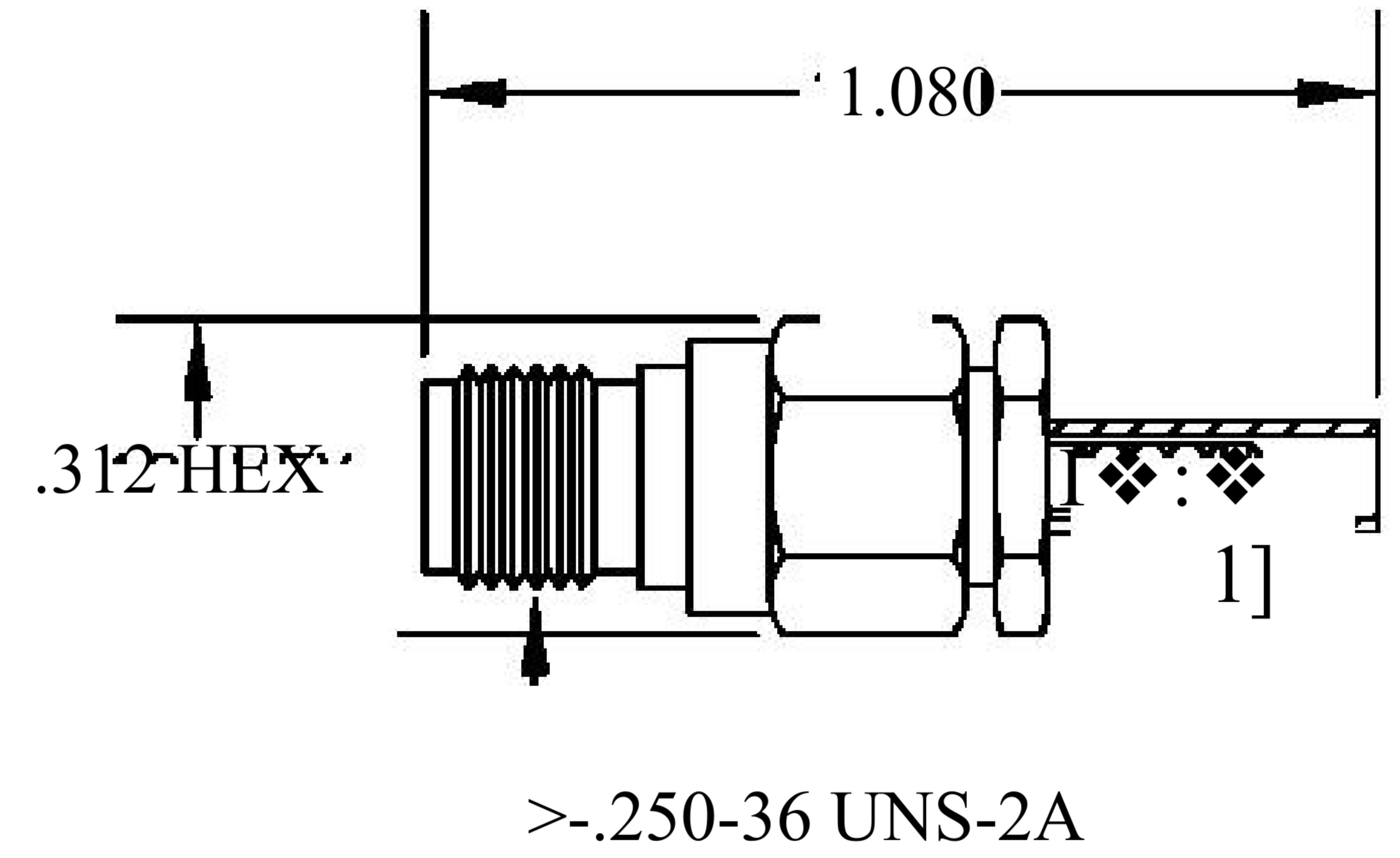

8th Floor, Building 1, Yongfu Science and Technology Center Industrial Park, Nanzha District 5, Humen, 523900, Dongguan, Guangdong, China.

Website: www.ebeestock.com
 Email: sales@ebeestock.com

COAXIAL & FIBER OPTICS

DWG TITLE	ET11421	DES_	sma-female-connector-solder-attachment-for-rg178-rg196-0011421
SIZE A FSCM NO. 53919 CAD FILE 073102 SCALE N/A			127

- NOTES:
1. UNLESS OTHERWISE SPECIFIED ALL DIMENSIONS ARE NOMINAL.
 2. ALL SPECIFICATIONS ARE SUBJECT TO CHANGE WITHOUT NOTICE AT ANY TIME.