

**MATERIALS**

<b>BODY</b>	<b>BRASS NICKEL PLATED</b>
<b>CONTACT</b>	<b>GOLD PLATED</b>
<b>INSULATOR</b>	<b>PTFE</b>
<b>FERRULE</b>	<b>GOLD PLATED</b>

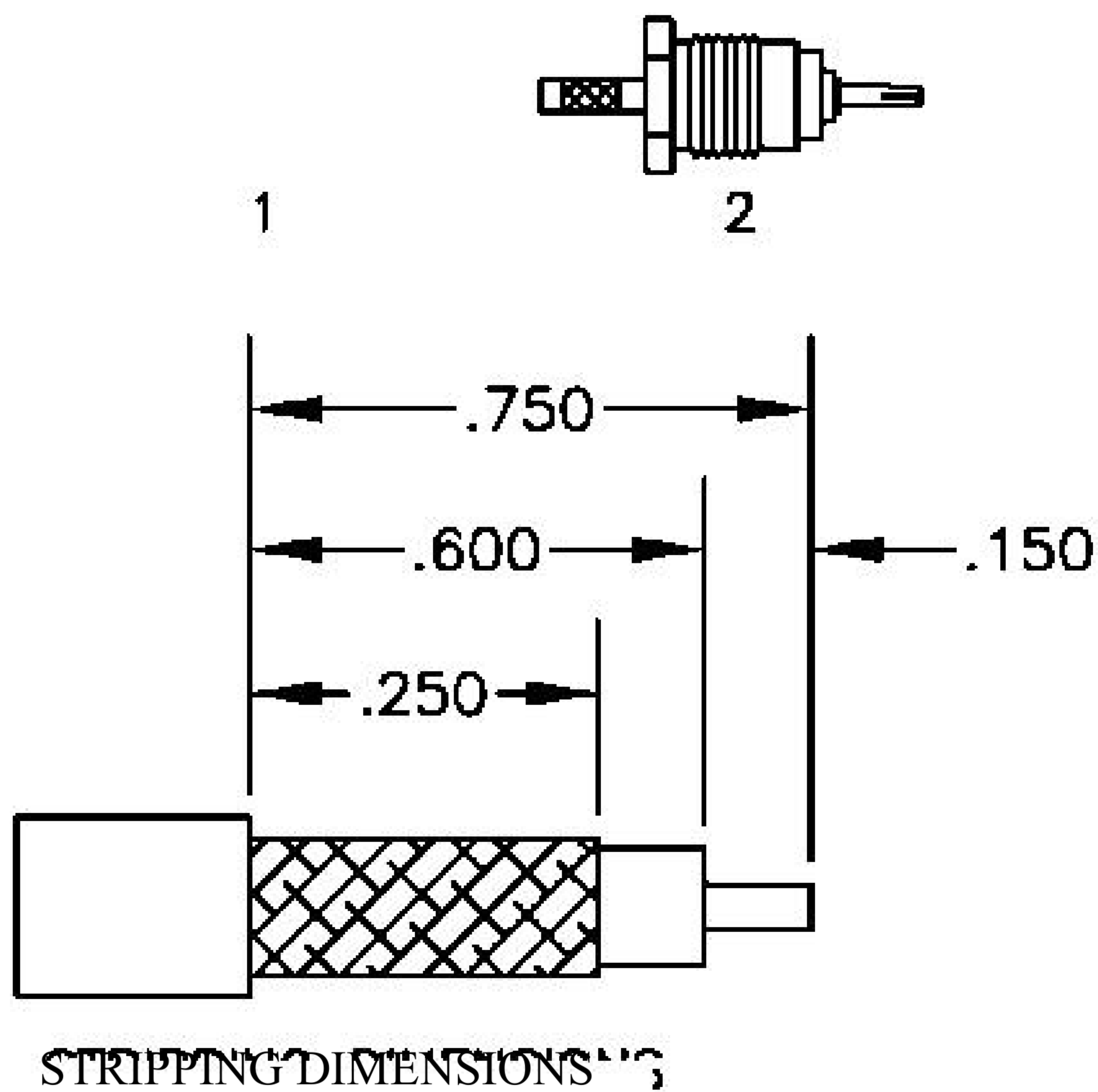
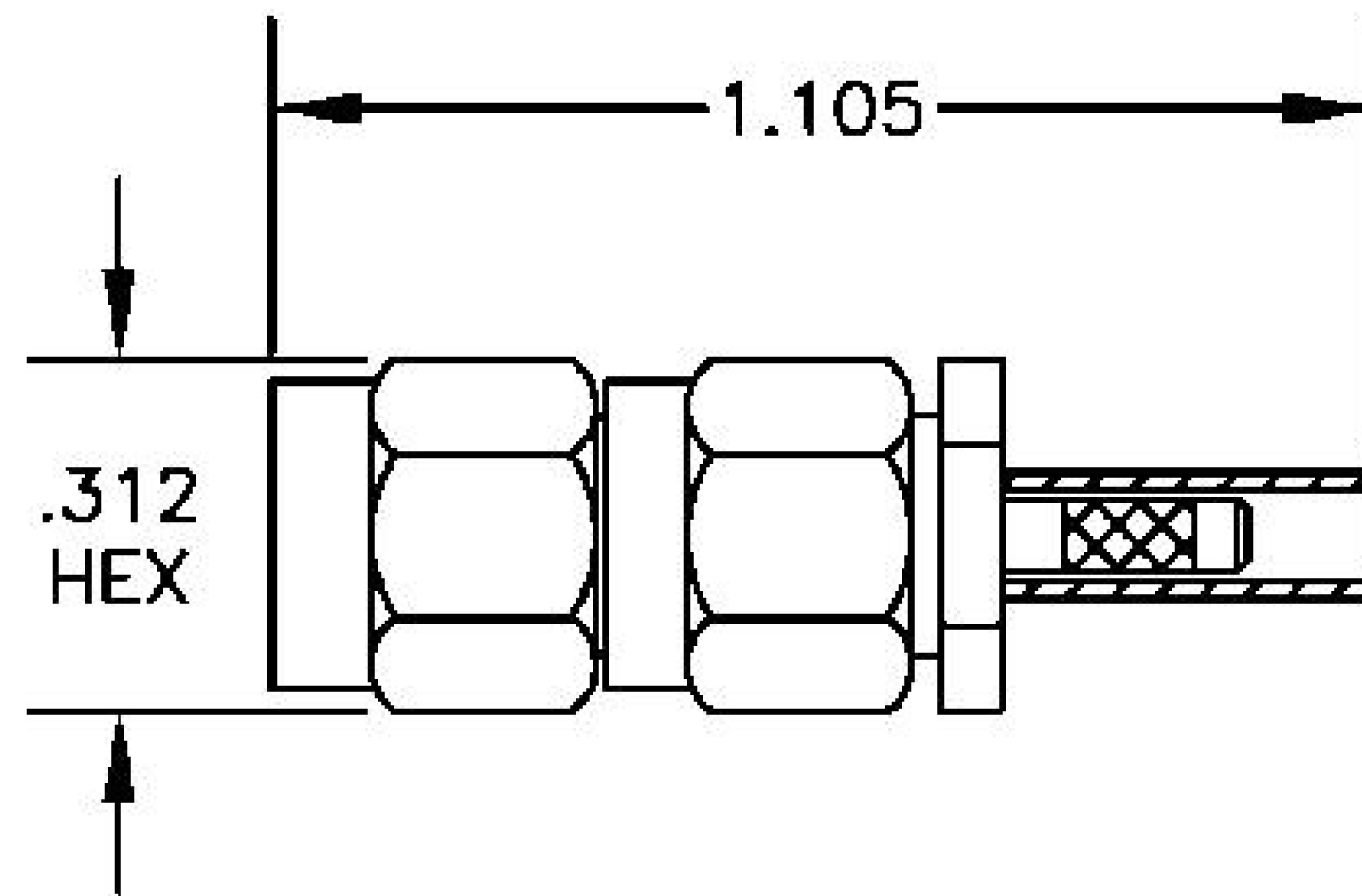

ASSEMBLY PROCEDURES

1. STRIP CABLE AS SHOWN & SLIDE FERRULE (1) ONTO CABLE. TIN CENTER CONDUCTOR.
2. ADD EXTENSION (2) BY SLIDING EXTENSION BETWEEN BRAID & DIELECTRIC. SLIDE FERRULE (1) OVER BRAID & SOLDER.
3. SOLDER CENTER CONDUCTOR THROUGH HOLE IN CONTACT. SLIDE ASSEMBLY INTO BODY & TIGHTEN.

8th Floor, Building 1, Yongfu Science and Technology Center Industrial Park

Nanzha District 5, Humen, 523900  
Dongguan, Guangdong, China.



8th Floor, Building 1, Yongfu Science and Technology Center Industrial Park, Nanzha District 5, Humen, 523900, Dongguan, Guangdong, China.

**Website:** [www.ebeestock.com](http://www.ebeestock.com)  
**Email:** [sales@ebeestock.com](mailto:sales@ebeestock.com)

**COAXIAL & FIBER OPTICS**

DWG TITLE	ET11431	DES_	rp-sma-male-connector-solder-attachment-for-rg178-rg196-0011431
-----------	---------	------	---

SIZE A | **FSCM NO. 53919** | CAD FILE 073102 | SCALE N/A | 127

**NOTES:**

1. UNLESS OTHERWISE SPECIFIED ALL DIMENSIONS ARE NOMINAL.
2. ALL SPECIFICATIONS ARE SUBJECT TO CHANGE WITHOUT NOTICE AT ANY TIME.