

MATERIALS	
BODY	BRASS NICKEL PLATED
CONTACT	GOLD PLATED
INSULATOR	PTFE

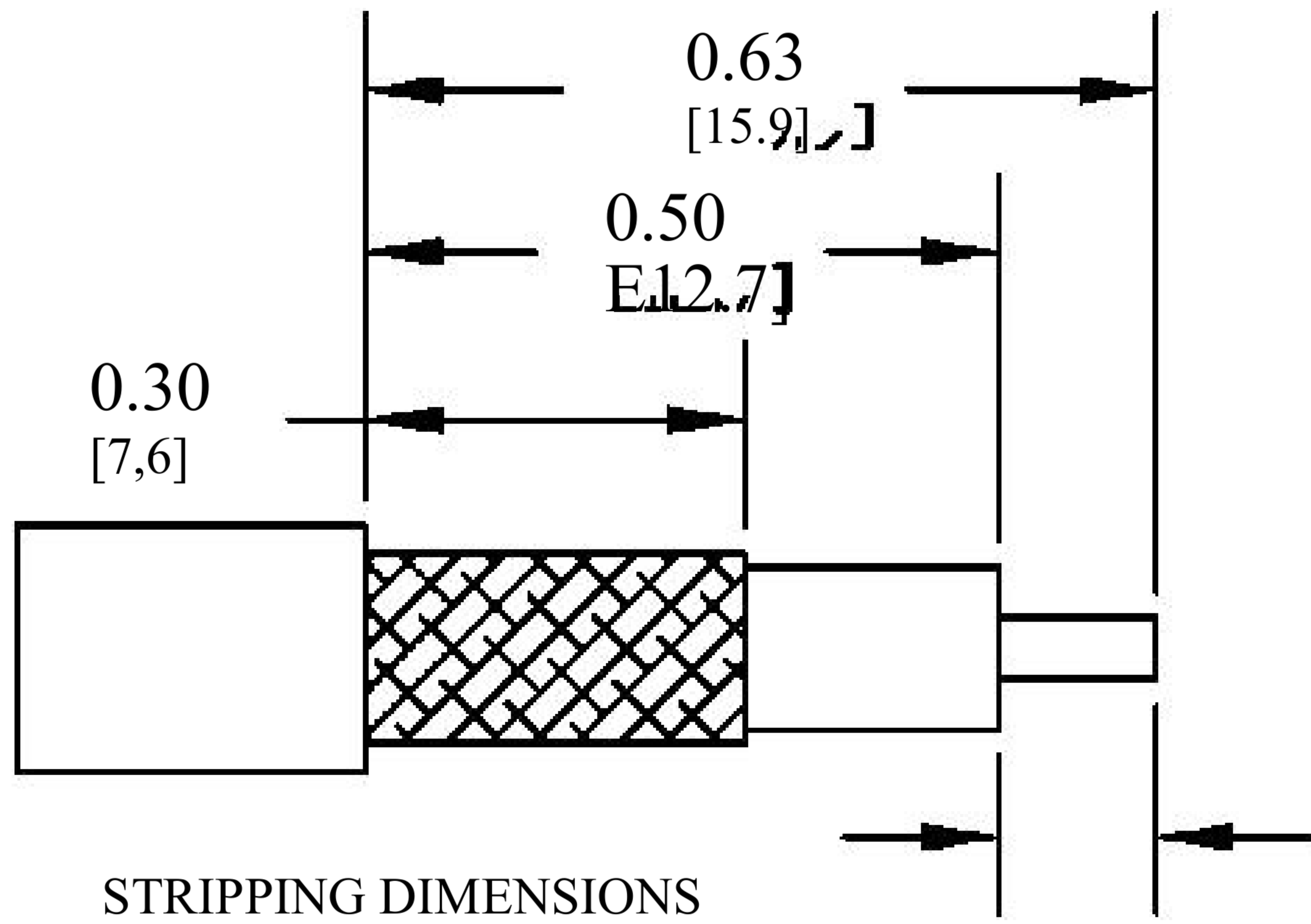
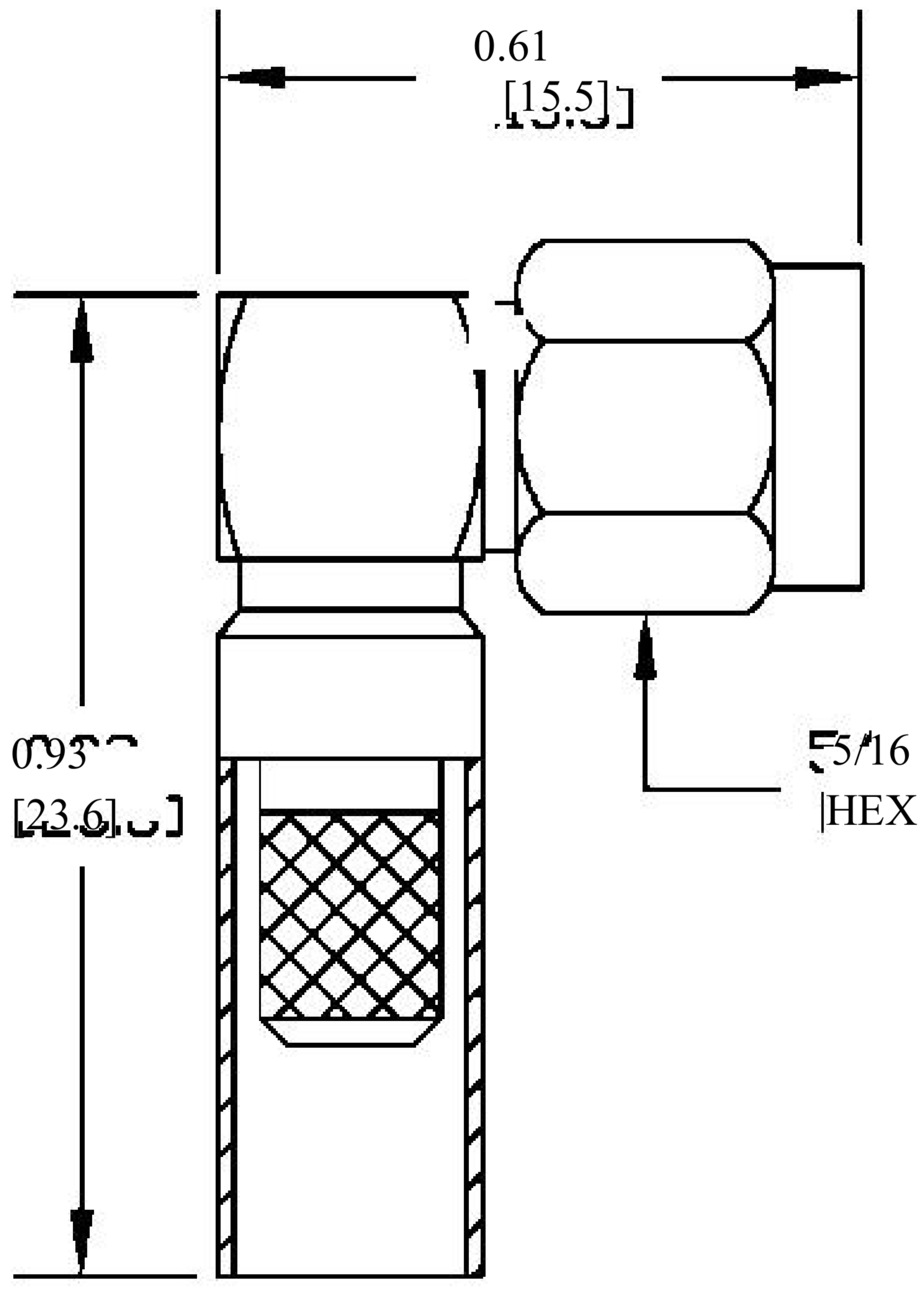

ASSEMBLY PROCEDURES

1. STRIP CABLE AS SHOWN
2. INSTALL CABLE INTO BODY OF CONNECTOR AND SOFT SOLDER CENTER CONDUCTOR IN PLACE
3. CRIMP FERRULE & PRESS CAP DOWN

CRIMP SIZE REQUIRED

0.13 [3,2] FERRULE: .213" HEX CRIMP



8th Floor, Building 1, Yongfu Science and Technology Center Industrial Park, Nanzha District 5, Humen, 523900, Dongguan, Guangdong, China.

Website: www.ebeestock.com
 Email: sales@ebeestock.com

COAXIAL & FIBER OPTICS

DWG TITLE	ET11436	DES_	rp-sma-male-right-angle-connector-crimp-solder-attachment-for-rg58-001 1436
-----------	---------	------	--

SIZE A | **FSCM NO. 53919** | CAD FILE 073102 | SCALE N/A | 127

- NOTES:
1. UNLESS OTHERWISE SPECIFIED ALL DIMENSIONS ARE NOMINAL.
 2. ALL SPECIFICATIONS ARE SUBJECT TO CHANGE WITHOUT NOTICE AT ANY TIME.

TOOL