

**MATERIALS**

<b>BODY</b>	<b>BRASS NICKEL PLATED</b>
<b>CONTACT</b>	<b>GOLD PLATED</b>
<b>INSULATOR</b>	<b>PTFE</b>
<b>FERRULE</b>	<b>SOLDER</b>

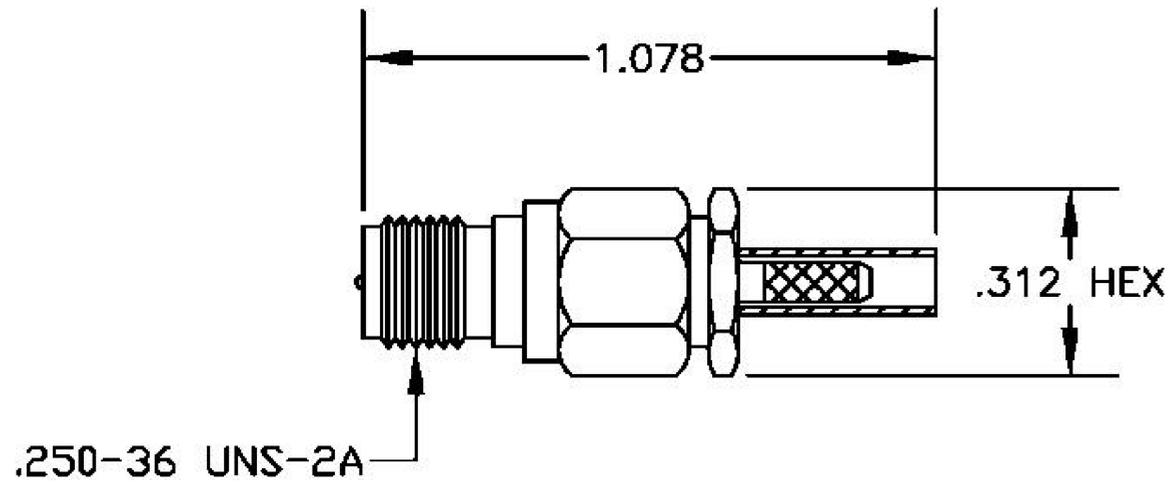

ASSEMBLY PROCEDURES

【臨,

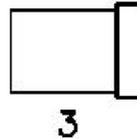

1. SLIDE FERRULE (1) & CLAMP NUT (2) OVER CABLE. STRIP CABLE AS SHOWN. TIN CENTER CONDUCTOR.

2. FLMR BRAID & INSERT EXTENSION (3) SLIDING UNDER BRAID. CENTER CONDUCTOR PROTRUDING THROUGH HOLE IN EXTENSION. SLIDE PTFE (4) OVER CENTER CONDUCTOR.

3. SOLDER CONTACT (5) TO CENTER CONDUCTOR. SLIDE FERRULE OVER BRAID & SOLDER. INSTALL CABLE ASSEMBLY INTO BODY & TIGHTEN.

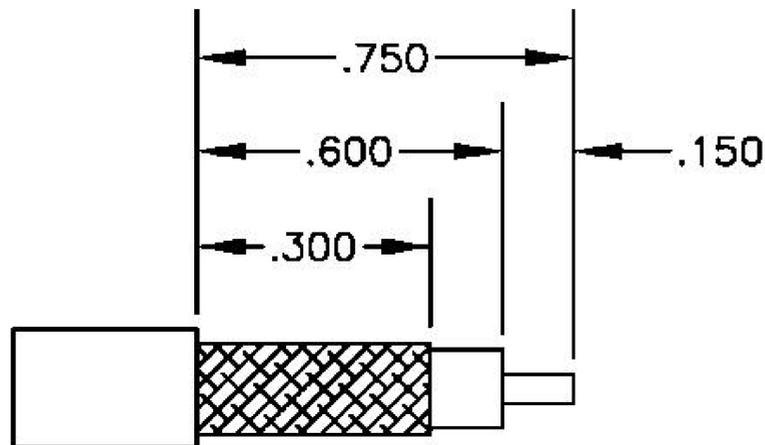

STRIPPING DIMENSIONS

CRIMP SIZE REQUIRED

FERRULE: .100" HEX CRIMP TOOL



8th Floor, Building 1, Yongfu Science and Technology Center Industrial Park, Nanzha District 5, Humen, 523900, Dongguan, Guangdong, China.

Website: [www.ebeestock.com](http://www.ebeestock.com)

Email: [sales@ebeestock.com](mailto:sales@ebeestock.com)

**COAXIAL & FIBER OPTICS**

DWG TITLE	ET11451	DES_	rp-sma-female-connector-solder-attachment-for-rg178-rg196-0011451
SIZE A   FSCM NO. 53919   CAD FILE 073102   SCALE N/A		127	

**NOTES:**

1. UNLESS OTHERWISE SPECIFIED ALL DIMENSIONS ARE NOMINAL.
2. ALL SPECIFICATIONS ARE SUBJECT TO CHANGE WITHOUT NOTICE AT ANY TIME.