

MATERIALS	
BODY	BRASS NICKEL PLATED
CONTACT	GOLD PLATED
INSULATOR	PTFE
FERRULE	GOLD PLATED

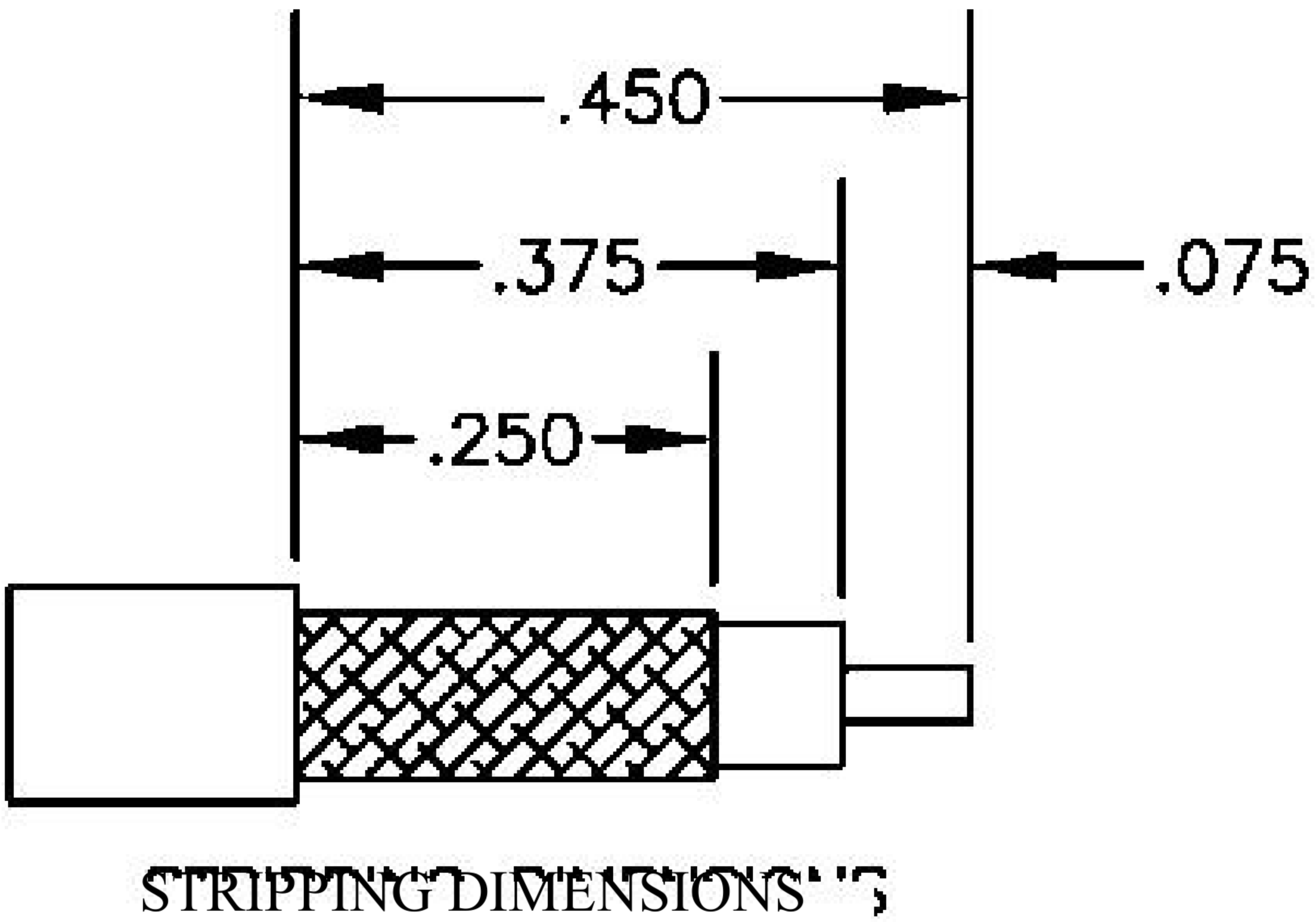

ASSEMBLY PROCEDURES

1. STRIP CABLE AS SHOWN & SLIDE FERRULE OVER CABLE.
2. INSTALL CABLE INTO BODY OF CONNECTOR AND SOFT SOLDER CENTER CONDUCTOR IN PUACE.
3. SOLDER FERRULE & PRESS CAP DOWN.

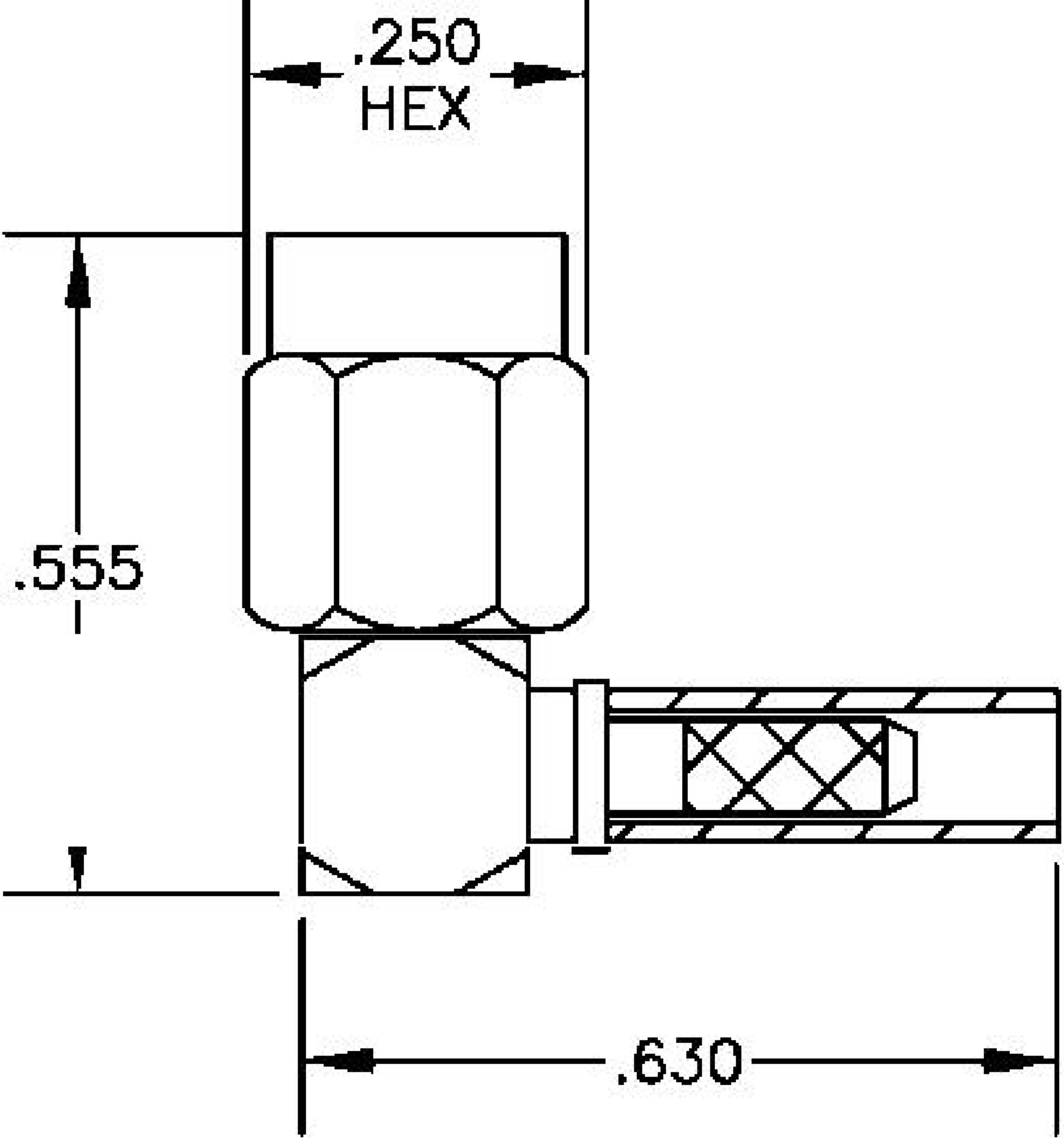

8th Floor, Building 1, Yongfu Science and Technology Center Industrial Park, Nanzha District 5, Humen,523900, Dongguan, Guangdong, China.

Website: www.ebeestock.com
 Email: sales@ebeestock.com

COAXIAL & FIBER OPTICS

DWG TITLE	ET11611	DES_	ssma-male-right-angle-connector-solder-attachment-for-rg178-rg196-0011 611
-----------	---------	------	---

SIZE A | FSCM NO. 53919 | CAD FILE 073102 | SCALE N/A | 127

- NOTES:
1. UNLESS OTHERWISE SPECIFIED ALL DIMENSIONS ARE NOMINAL.
 2. ALL SPECIFICATIONS ARE SUBJECT TO CHANGE WITHOUT NOTICE AT ANY TIME.