

**MATERIALS**

<b>BODY</b>	<b>BRASS NICKEL PLATED</b>
<b>CONTACT</b>	<b>SILVER PLATED</b>
<b>INSULATOR</b>	<b>PTFE</b>
<b>SOLDER ADAPTER</b>	<b>BRASS GOLD PLATED</b>

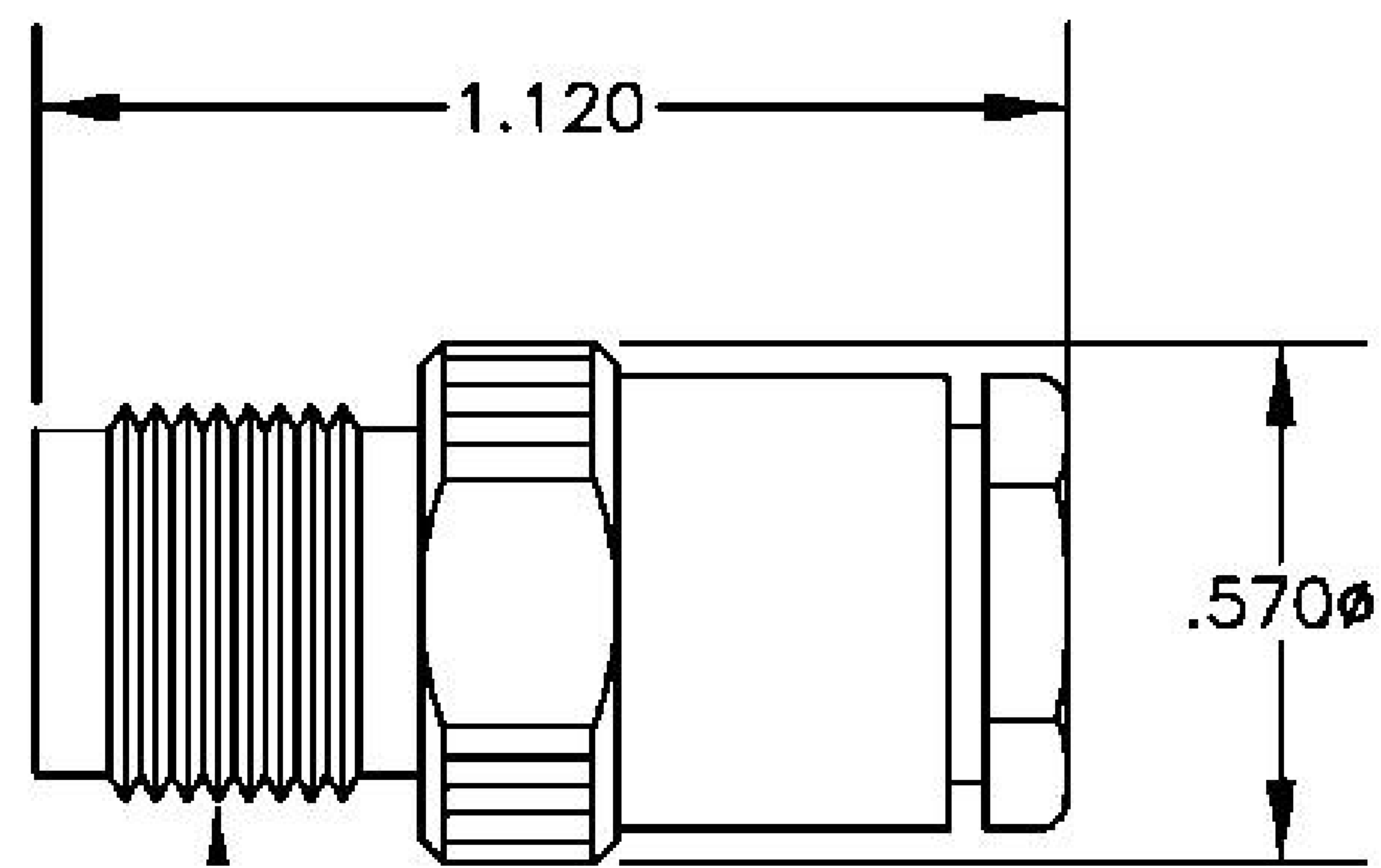

.4375-28 UNEF-2A -1

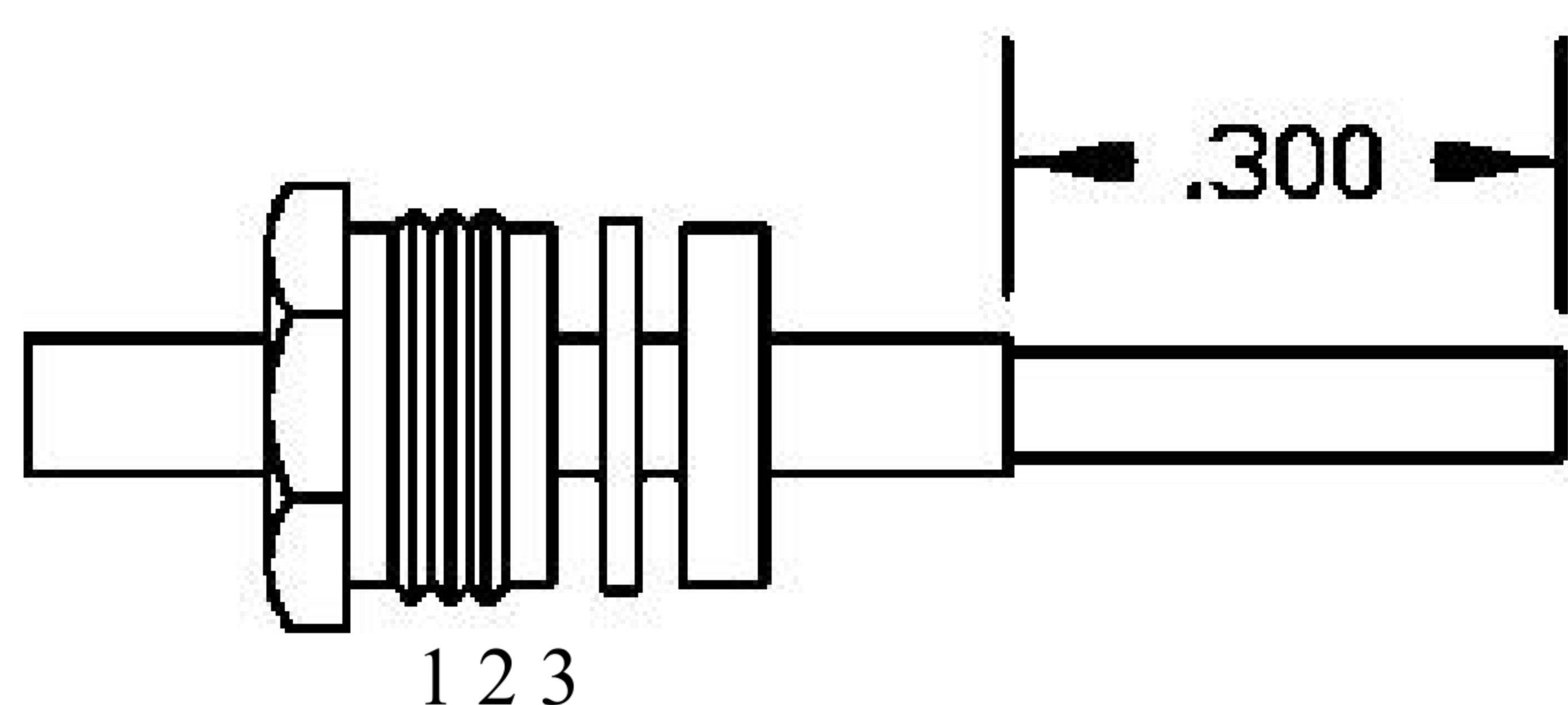

ASSEMBLY (A)

ASSEMBLY PROCEDURES

1. SLIDE CLAMP NUT (1), WASHER (2) & GASKET (3) OVER CABLE. STRIP CABLE AS SHOWN IN ASSEMBLY (A). DO NOT CUT DIELECTRIC.

2. SLIDE ADAPTER (4) OVER CABLE UNTIL ADAPTER (4) BOTTOMS ON OUTER CONDUCTOR. SOLDER ADAPTER (4) TO OUTER CONDUCTOR USING MINIMUM HEAT.

STRIP CABLE AS SHOWN IN ASSEMBLY (B).  
 3. SOLDER CONTACT TO CENTER CONDUCTOR. SLIDE ASSEMBLY FORWARD & TIGHTEN TO BODY.

.10  
0

ASSEMBLY (B)



8th Floor, Building 1, Yongfu Science and Technology Center Industrial Park, Nanzha District 5, Humen, 523900, Dongguan, Guangdong, China.

Website: [www.ebeestock.com](http://www.ebeestock.com)

Email: [sales@ebeestock.com](mailto:sales@ebeestock.com)

**COAXIAL & FIBER OPTICS**

DWG TITLE ET11686	DES_ tnc-female-connector-clamp-solder-attachment-for-pe-sr405al-pe-sr405fl-rg405-0011686
----------------------	--

SIZE A | **FSCM NO. 53919** | CAD FILE 073102 | SCALE N/A | 127

**NOTES:**

- UNLESS OTHERWISE SPECIFIED ALL DIMENSIONS ARE NOMINAL.
- ALL SPECIFICATIONS ARE SUBJECT TO CHANGE WITHOUT NOTICE AT ANY TIME.