

MATERIALS

BODY	BRASS NICKEL PLATED
CONTACT	GOLD PLATED
INSULATOR	PTFE
SOLDER ADAPTER	GOLD PLATED

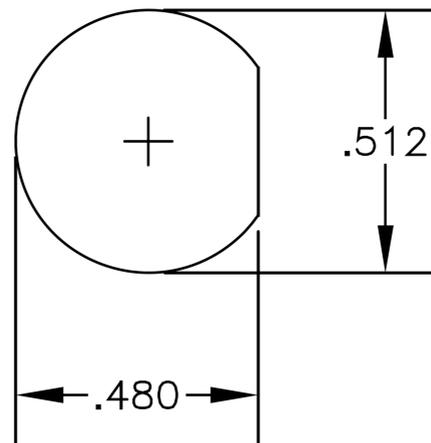

MOUNTING HOLE

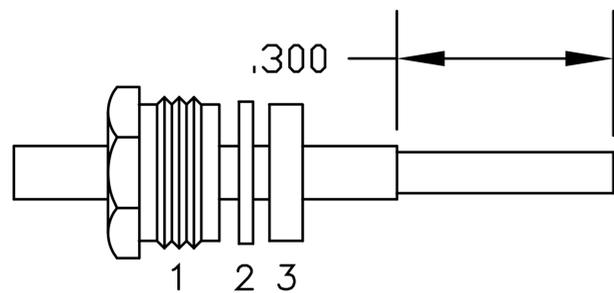
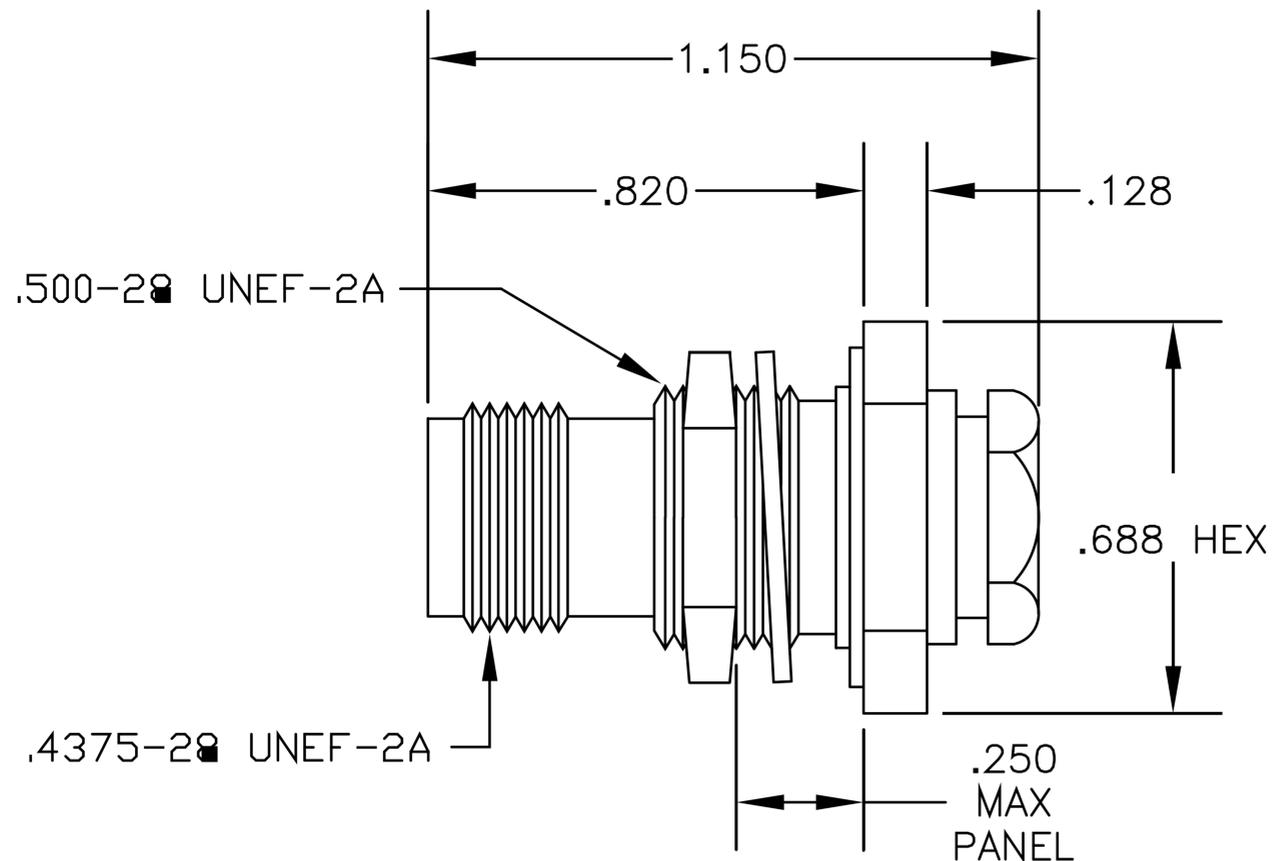

ASSEMBLY (A)

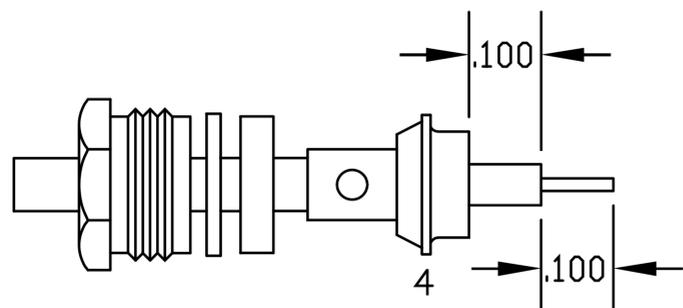

ASSEMBLY (B)

ASSEMBLY PROCEDURES

1. SLIDE CLAMP NUT (1), WASHER (2) & GASKET (3) OVER CABLE. STRIP CABLE AS SHOWN IN ASSEMBLY (A). DO NOT CUT DIELECTRIC.
2. SLIDE ADAPTER (4) OVER CABLE UNTIL ADAPTER (4) BOTTOMS ON OUTER CONDUCTOR. SOLDER ADAPTER (4) TO OUTER CONDUCTOR USING MINIMUM HEAT.
3. STRIP CABLE AS SHOWN IN ASSEMBLY (B). SOLDER CONTACT TO CENTER CONDUCTOR. SLIDE ASSEMBLY FORWARD & TIGHTEN TO BODY.



8th Floor, Building 1, Yongfu Science and Technology Center Industrial Park, Nanzha District 5, Humen, 523900, Dongguan, Guangdong, China.

Website: www.ebeestock.com

Email: sales@ebeestock.com

COAXIAL & FIBER OPTICS

DWG TITLE

ET11690

DES_

tnc-female-bulkhead-connector-clamp-solder-attachment-for-pe-sr405al-p
e-sr405fl-rg405-480-inch-d-hole-0011690

SIZE A | FSCM NO. 53919 | CAD FILE 073102 | SCALE N/A |

127

NOTES:

1. UNLESS OTHERWISE SPECIFIED ALL DIMENSIONS ARE NOMINAL.
2. ALL SPECIFICATIONS ARE SUBJECT TO CHANGE WITHOUT NOTICE AT ANY TIME.